



OKIDATA OKIPAGE4w LED Page Printer Service Manual

Adobe Acrobat printable reference
copy of the OKIDATA Service Training Manual.
09/17/97

Note: This Adobe Acrobat version of the Okidata Service Training Manual was built with the pictures rendered at 300 dpi, which is ideal for printing, but does not view on most displays well.

Okidata is a registered trademark, and OkiPage is a trademark of Oki Electric Industry Co., Ltd. HP, LaserJet and PCL5e are trademarks of Hewlett-Packard Co. Adobe and Acrobat are trademarks of Adobe Systems Incorporated.

Copyright 1997, Okidata, Division of OKI America, Inc. All rights reserved. See the OKIDATA Business Partner Exchange (BPX) for any updates to this material. (<http://bpx.okidata.com>)

Service Guide OKIPAGE4w**0 General Manual Information**

Front Cover	1
Preface	2

1 Configuration

CONFIGURATION	3
Printer Configuration	4
Specification	5
Safety Standards - Certification Label	6
...Warning Label	7

2 Operation Description

OPERATION DESCRIPTION	8
Main Control Board	9
Power Supply Unit	10
High-Voltage Power Supply Board	11
Electro-Photographic Processor	12
Electro-Photographic Process	13
...Explanation of Each Operation - Hopping	14
...Printing and warm-up	15
...Charging	16
...Exposure	17
...Development	18
...Transfer	19
...Fusing	20
...Cleaning	21
Paper Jam Detection	22
Toner Low Detection	23
Cover Open	24

3 Parts Replacement

Parts Replacement	25
Precautions for Parts Replacement	26
Parts Layout	27
...Base Frame Unit	28
...Base Plate Unit	29
Replacing Parts	30
...Extend Plate	31
...LED Head and Head Spring	32
...Transfer Roller	33
...Upper Cover Assy	34
...High-Voltage Power Supply Board	35
...Top Cover Assy and Flat Cable Assy	36
...Paper Holder	37
...Side Plate M and Idle Gear	38
...Registration Roller	39
...Eject Roller Shaft and Eject Roller	40
...Fuser Assy	41
...Pressure Roller B (Back Up Roller)	42
...Separator Guide	43
...Pulse Motor (Main)	44
...Hopping Shaft Assy	45

Table of Contents**Page**

....Paper Sensor E, Paper Sensor Exit and Toner Sensor Assy	46
....Base Plate	47
4 Adjustment	
Adjustment	48
....Adjustment Types and Functions	49
....Adjustment When Replacing a Part	50
5 Periodical Maintenance	
Periodical Maintenance - Periodical Replacement Parts	51
Cleaning	52
6 Troubleshooting Procedures	
Troubleshooting Procedures - Troubleshooting Tips	53
Check Points Before Correcting Image Problems	54
Notes When Correcting Image Problems	55
Preparation Before Troubleshooting	56
Troubleshooting	57
....Status Monitor Message List	58
....Status Message Troubleshooting	59
.....The OKIPAGE 4w malfunctions after the power supply has been turned on.	60
.....[JAM error] - Paper input jam	61
.....[JAM error] - Paper feed jam	62
.....Paper exit jam	63
.....Paper size error	64
.....Fuser assy error	65
....Image Troubleshooting	66
.....An image is light or blurred entirely.	67
.....Dark background density	68
.....Paper is blank.	69
.....Vertical black band/stripe	70
.....Cyclic defect	71
.....Print voids.	72
.....Poor fusing	73
.....Vertical white band/stripe	74
.....Figure 6-4	75
.....Figure 6-5	76
7 Wiring Diagram	
Wiring Diagram - Interconnect Signal Diagram	77
PCB Layout	78
8 Parts List	
Cover Assy Upper	79
Base Frame Unit	80
Base Plate Unit	81
A Local Printing	
Local Printing	82
B Parallel Interface	
Parallel Interface - (1) Connector	83
Cable	84
Parallel I/F signals	85
Signal level	86
Interface circuit	87

Table of Contents

Page

Timing charts	88
C Maintenance Utility	
Maintenance Utility - Outline Of Maintenance Utility	89
ROLE OF MAINTENANCE UTILITY	90
OUTLINE OF MAINTENANCE UTILITY FUNCTIONS	91
DETAIL OF EACH FUNCTION - Engine Menu Setting	92
....Engine Counter	93
....Exit	94
....Printer Status	95
....Test Print	96
....Option	97
....About	98
....Reload	99



Service Guide OKIPAGE4w

Chapter 0 General Manual Information

PREFACE

This Service Manual describes the maintenance procedures for OKIPAGE 4w LED Page Printers. This manual is written for use by service personnel. Refer to the customer documentation for handling and operating procedures.

Copyright 1997, Okidata, Division of OKI America, Inc. All rights reserved. See the OKIDATA Business Partner Exchange (BPX) for any updates to this material. (<http://bpx.okidata.com>)

1. CONFIGURATION

1.1 System Configuration

The OKIPAGE 4w consists of a control block, a power supply unit, and an engine block. (See Figure 1-1.)

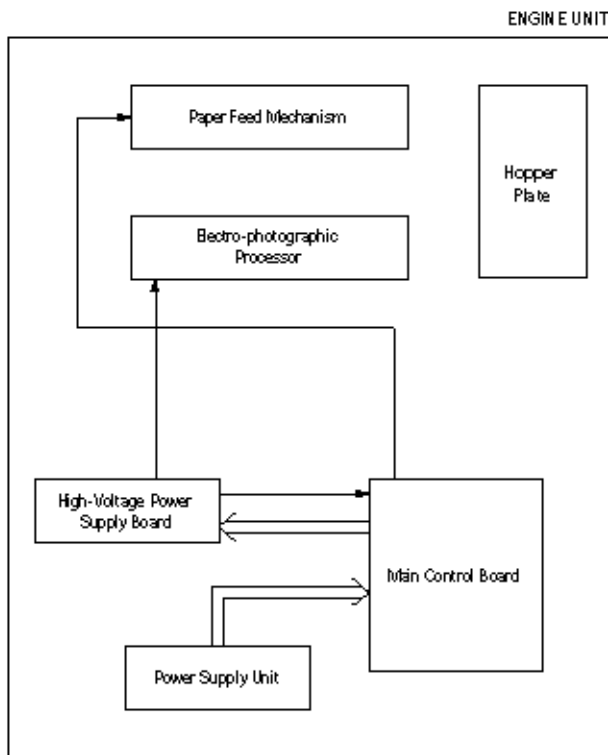

Figure 1-1

Printer Configuration

The printer unit consists of the following five hardware components:

- Electro-Photographic Processor
- Paper Feeder
- Main Control Board
- High-Voltage Power Supply Board
- Power Supply Unit

Figure 1-2 is the configuration of the printer unit.

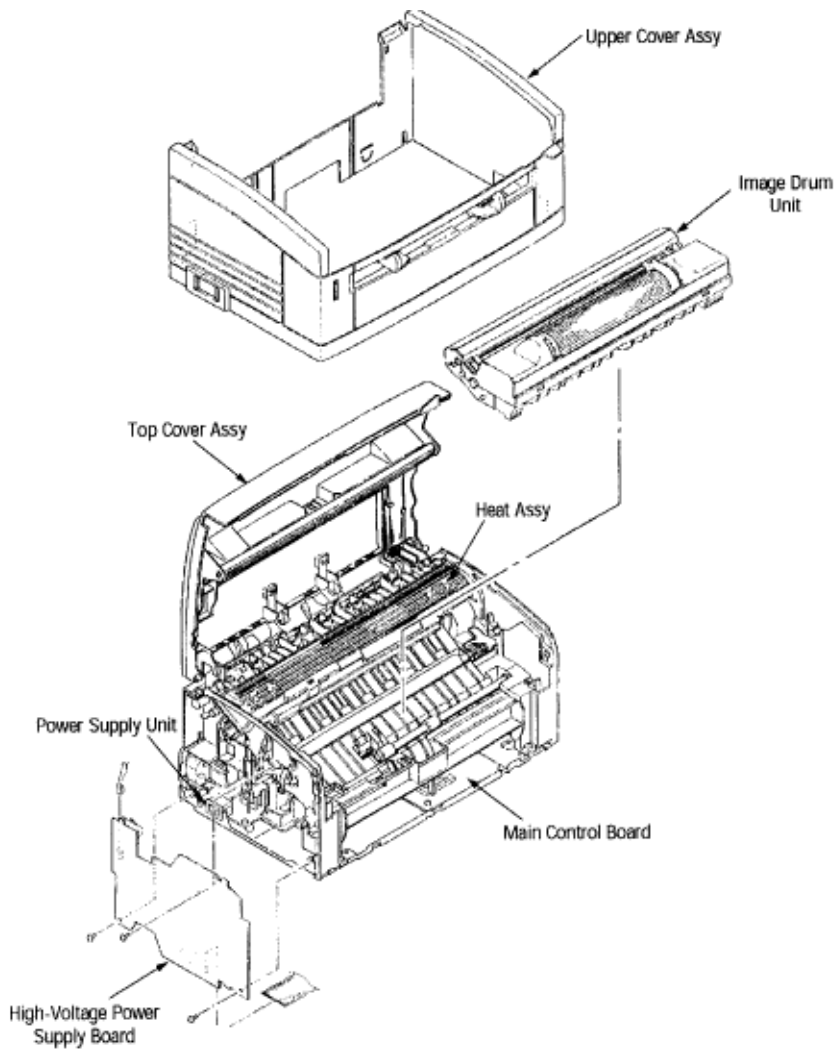

Figure 1-2

Copyright 1997, Okidata, Division of OKI America, Inc. All rights reserved. See the OKIDATA Business Partner Exchange (BPX) for any updates to this material. (<http://bpx.okidata.com>)



Service Guide OKIPAGE4w

Chapter 1 Configuration

Specification

- (1) Type Desktop
- (2) Outside dimensions Height 5.9" (150 mm) (excludes protruding Width 12.2" (310 mm) portion) Depth 7.5" (191 mm)
- (3) Weight 1.71 lb (3.8 kg)
- (4) Development method Dry non-magnetic development system Exposure method LED stationary head
- (5) Paper used Type
- Standard paper
 - Xerox 4200 (20 lbs)
 - Application paper (manual face-up feed)
 - Label
 - Envelope
 - OHP paper (Transparency)
- Size 14" (355.6 mm) (Max.) x 8.5" (215.9 mm)
- Thickness
- Automatic feed: 16 to 28 lbs (60 to 90 g/m²)
 - Manual feed: Label, Envelope, OHP paper (transparency)
- (6) Printing speed First print: 25 seconds (A4) (after warm-up) Continuous print: 4 sheets/minute (A4) Warm-up time: 40 seconds (120 VAC for ODA, 230 VAC for OEL/INT) (at room temperature 77 °F (25 °C))
- (7) Paper feeding method Automatic paper feed or manual paper feed
- (8) Paper delivery method Face down
- (9) Resolution 300 dpi x 300 dpi, 600 dpi x 600 dpi (quasi)
- (10) Power input 230 VAC +15%, -14% (for OEL/INT) 120 VAC +6%, -15% (for ODA)
- (11) Power consumption Peak: 450W Typical operation: 100W Idle: 30W Power save mode: 5W
- (12) Temperature and humidity

	Temperature	Humidity
During operation	10 to 32 °C	20 to 80% RH (relative humidity)
In storage	-10 to +43 °C	10 to 90% RH (relative humidity) No condensation is permissible.

Caution: Temperature and humidity in storage are measured with the OKIPAGE 4w packed; they are valid for one year.

(13) Noise During operation: 48 dB (A) or less Standby: 38 dB (A) or less

(14) Consumables Toner cartridge kit 1,000 (5% duty) Image drum cartridge 10,000 (at continuous printing)

Copyright 1997, Okidata, Division of OKI America, Inc. All rights reserved. See the OKIDATA Business Partner Exchange (BPX) for any updates to this material. (<http://bpx.okidata.com>)



Service Guide OKIPAGE4w

Chapter 1 Configuration

Safety Standards

Certification Label

The safety certification label is affixed to the following location of the OKIPAGE 4w:

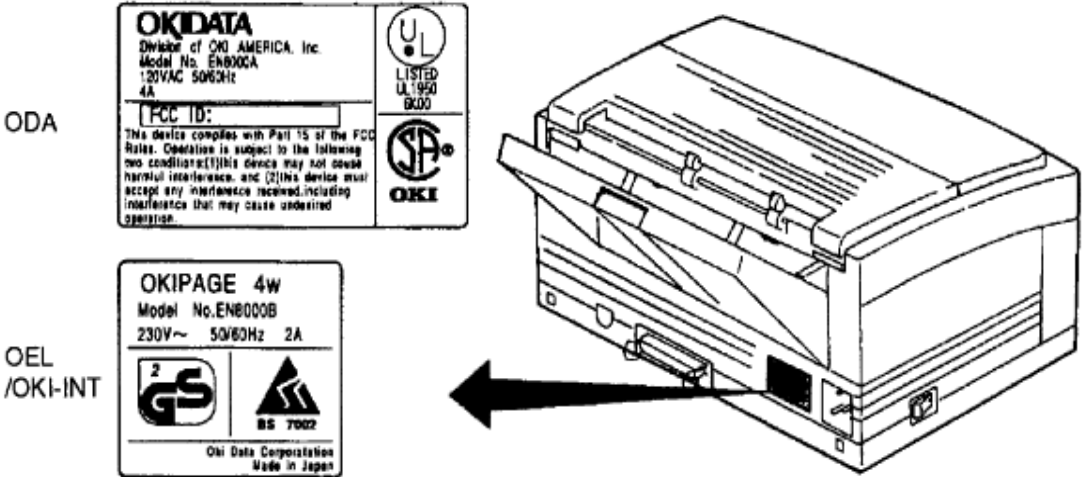

Warning Label

Warning labels are affixed to the locations that may cause bodily injury.

During maintenance, do work with enough care while following instructions on these warning labels.

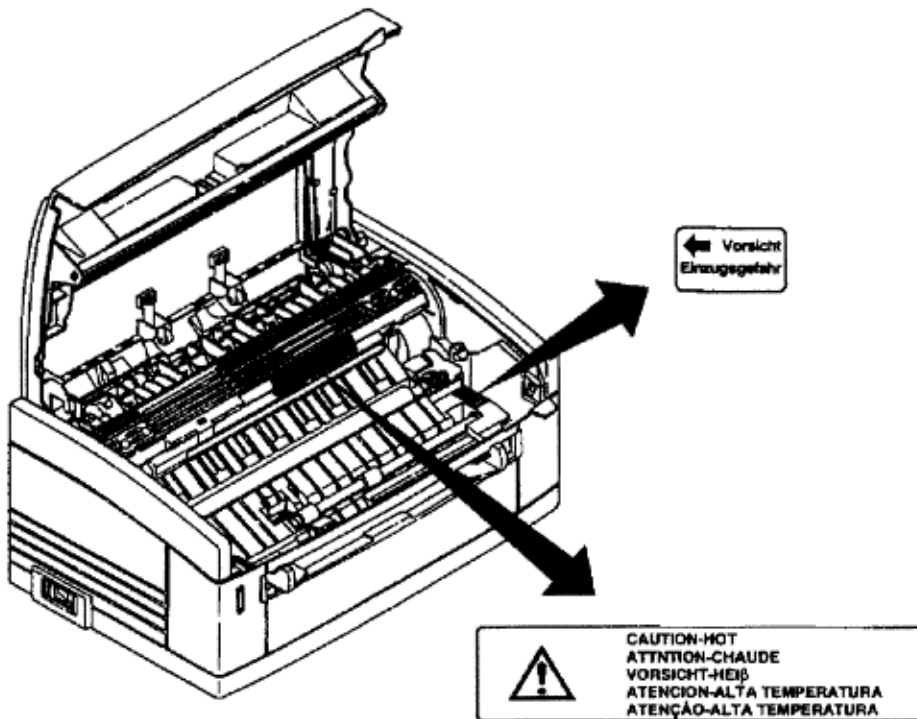

OPERATION DESCRIPTION

The OKIPAGE 4w consists of a main control board, a high-voltage power supply board, a power supply unit, and an electro-photographic processor. The OKIPAGE 4w receives print data from a higher-level interface and sequentially stores it in memory. The OKIPAGE 4w decodes and edits the received data while storing print data from the interface in memory. It sequentially transfers the edited data to the LED head for each dot line. The electro-photographic processor then prints the data on sheets of paper.

The display of the higher-level host is used for device operation and status display.

Figure 2-1 is the block diagram of the OKIPAGE 4w.

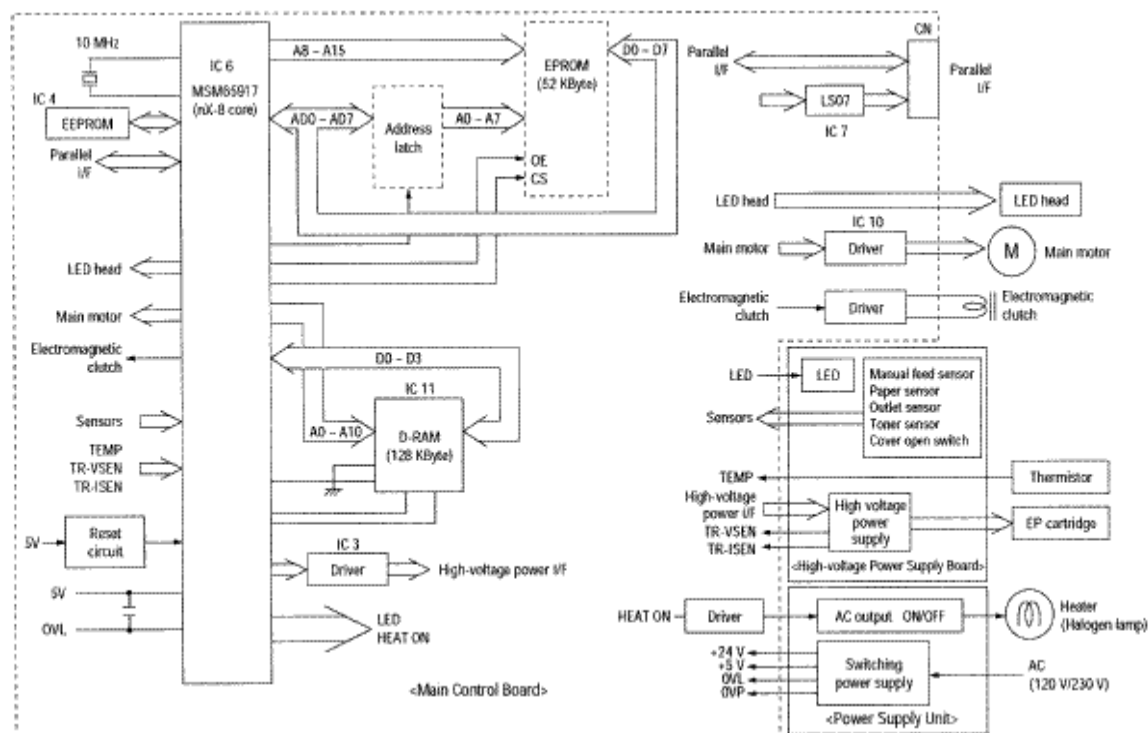

Figure 2-1 Block Diagram



Service Guide OKIPAGE4w

Chapter 2 Operation Description

Main Control Board

The main control board consists of a one-chip CPU, a program ROM, a DRAM, an EEPROM, a host interface circuit, and a mechanism driving circuit. The mechanism driving circuit consists of an LED head, a main motor, and an electromagnetic clutch.

(1) One-chip CPU

The one-chip CPU is a custom CPU (8-bit internal bus, 8-bit external bus, 10-MHz clock) incorporating mask ROM and CPU peripheral devices. This CPU has the functions listed in the table below.

Built-in Device	Function
DRAM controller	Controls DRAM.
DMA controller	Transfers image data from Parallel I/F to DRAM, from DRAM to a video output port and between CPU and DRAM.
Parallel interface controller	Controls the parallel interface.
Video output port LED STB output port	Controls LED head.
Timer	Generates various control timing signals for monitoring paper feeding and paper size.
I/O port	Inputs and outputs the sensor signals and motor signals, etc. Also performs I/O for EEPROM.
A/D converter	Inputs the feedback signals from a high-voltage generation circuit and thermistor signal.

(2) Program ROM

Program ROM contains a program for the equipment. EPROM is used as program ROM. When mask ROM in the one-chip CPU explained in (1) above is valid, the EPROM is not mounted. (For details on short wiring setting, see Section 7.2.)

(3) DRAM

DRAM is used as resident memory.

(4) EEPROM

EEPROM holds the following data:

- Menu data
- Counter value
- Adjustment value

(5) Parallel interface

The parallel interface receives parallel data from the host; it conforms to the IEEE1284 specification.

Copyright 1997, Okidata, Division of OKI America, Inc. All rights reserved. See the OKIDATA Business Partner Exchange (BPX) for any updates to this material. (<http://bpx.okidata.com>)



Service Guide OKIPAGE4w

Chapter 2 Operation Description

Power Supply Unit

The power supply unit supplies +5 V and +24 V to the main control board from 230 VAC /120 VAC.

Output voltage	Application
+5 V	Used to generate a logic circuit and a high voltage.
+24 V	Used to drive the motor and electromagnetic clutch.

The power supply unit also contains a heater drive circuit.

Copyright 1997, Okidata, Division of OKI America, Inc. All rights reserved. See the OKIDATA Business Partner Exchange (BPX) for any updates to this material. (<http://bpx.okidata.com>)

High-Voltage Power Supply Board

(1) High-Voltage power supply circuit

The high-voltage power supply circuit generates the following voltages required for the electro-photographic processor from +5 V according to the control sequence from the main control board. When the cover is open, +5 V supply is automatically interrupted to stop high-voltage output.

Output	Voltage	Application
CH	-1.35 KV	Voltage to be applied to a charge roller.
DB	-300 V/+300 V	Voltage to be applied to a developing roller.
SB	-450 V/0 V	Voltage to be applied to a sponge roller.
CB	+400 V	Voltage to be applied to a cleaning roller.
TR	+500 V ~ +3.5 KV- 750 V	Voltage to be applied to a transfer roller.

Caution: The TR voltage varies with medium and transfer roller impedance.

(2) Sensors

The high-voltage power supply board consists of the high-voltage power supply circuit that supplies power to the electro-photographic processor system and the photosensor that detects a paper feeding system and toners.

Figure 2-2 shows the sensor layout drawing.

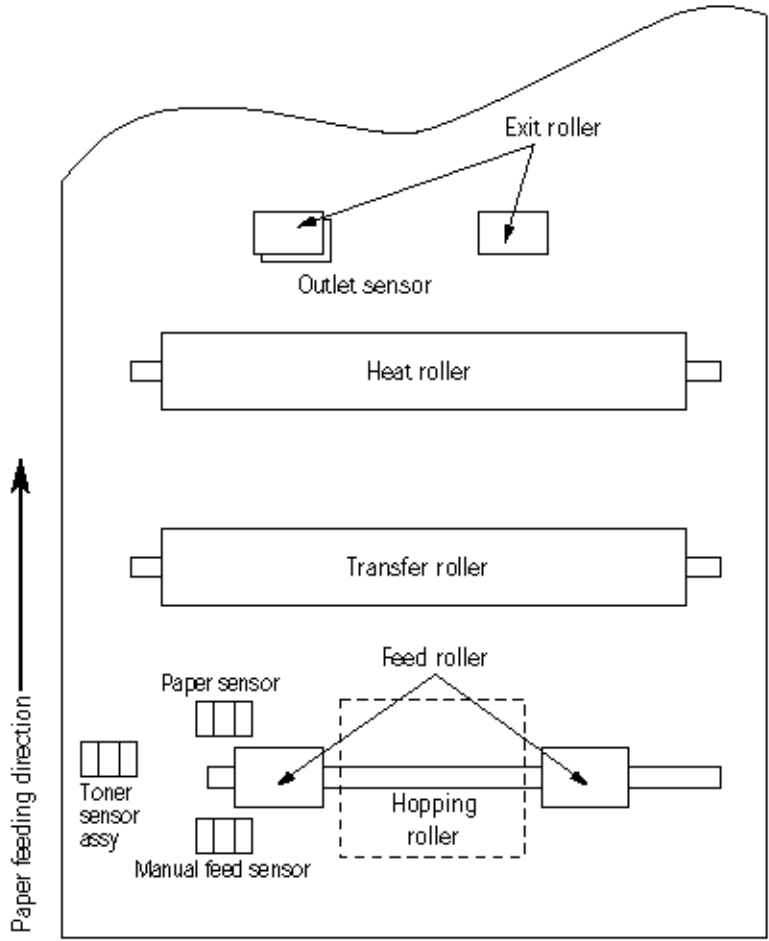

Figure 2-2

Sensor	Function	Sensing State
Manual feed sensor	Monitors whether paper was inserted into the manual feed sensor section.	ON: Paper exists. OFF: No paper exists.
Paper sensor	Detects the leading edge of the paper. Monitors paper feeding.	ON: Paper exists. OFF: No paper exists.
Outlet sensor	Monitors paper feeding and the paper size according to the paper sensor arrival and passing time.	ON: Paper exists. OFF: No paper exists.
Toner sensor	Detects the low toner status.	ON (long): Toner low OFF (short): Toner high

Electro-Photographic Processor

The electro-photographic processor prints out the image data sent from the main control board on sheets of paper. Figure 2-3 shows the layout of the electro-photographic processor.

(1) Image drum unit

The image drum unit makes toner adhere to the electrostatic latent image with static electricity. This electrostatic latent image is formed by light from the LED heads.

(2) Electromagnetic clutch

The electromagnetic clutch controls the rotation of the hopping roller according to signals from the control board.

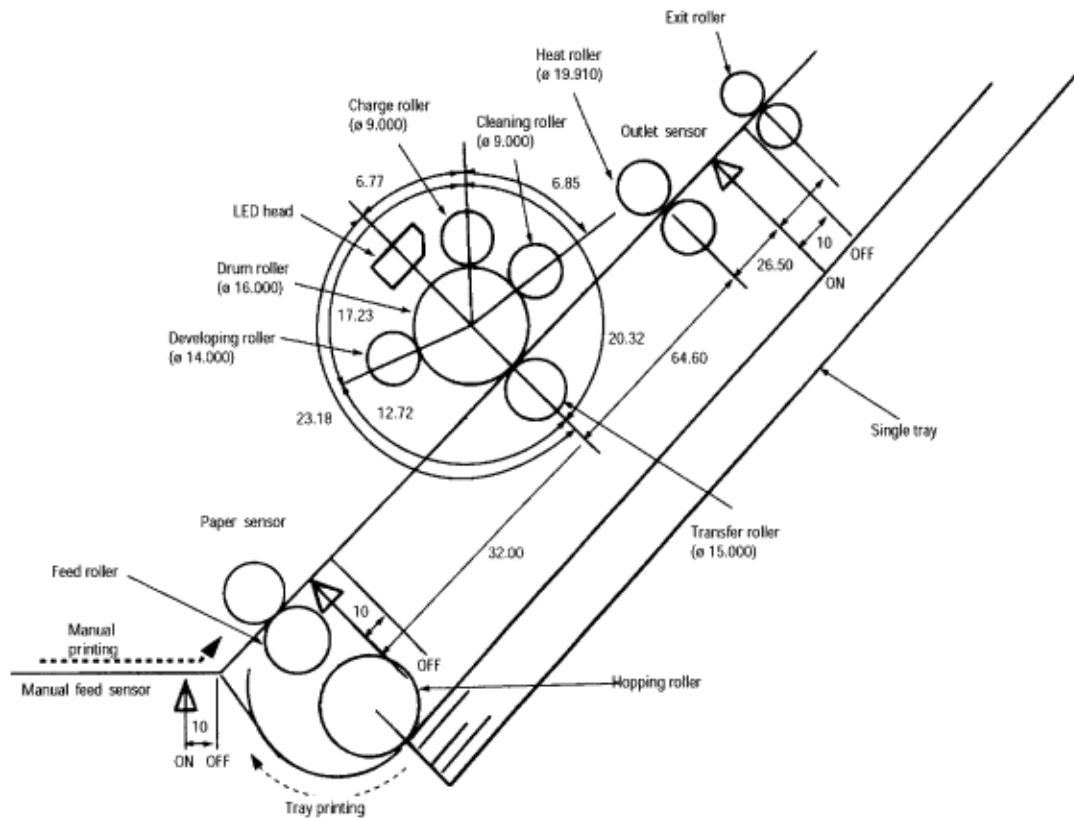

Figure 2-3 Layout Drawing of Electro-Photographic Processor

(3) Pulse motor (Main)

This pulse motor of 48 steps/rotation is two-phase controlled by the signal from the main control board; it controls feeding by changing rotation direction and turning on/off the electromagnetic clutch. The relationship between the main motor, electromagnetic clutch, regist gear, drum gear, and hopping roller is shown in the table below and on the subsequent pages.

Main Motor	Electromagnetic Clutch	Hopping Roller	Regist Gear	Drum Gear	Operation
Normal rotation	OFF	Non-rotation	Non-rotation	Rotation	Warm-up
Reverse rotation	ON	Rotation	Rotation	Rotation	Hopping
Reverse rotation	OFF	Non-rotation	Rotation	Rotation	Printing

(4) LED head

The shift and latch registers receive image data from the main control board for each dot line. They control the 2,560 or 2,496 LEDs, which illuminate the image drum.

(5) Fuser Assy

The fuser Assy consists of a heater, a heat roller, a thermistor, and a thermostat.

The power supply unit applies AC voltage to the heater according to the HEATON signal from the main control board; this heats the heat roller. The main control board monitors the heat roller temperature via the thermistor and keeps the temperature constant by turning on/off the heater voltage.

If the heat roller temperature rises abnormally, the thermostat in the heater voltage supply circuit cuts off the AC voltage supply.

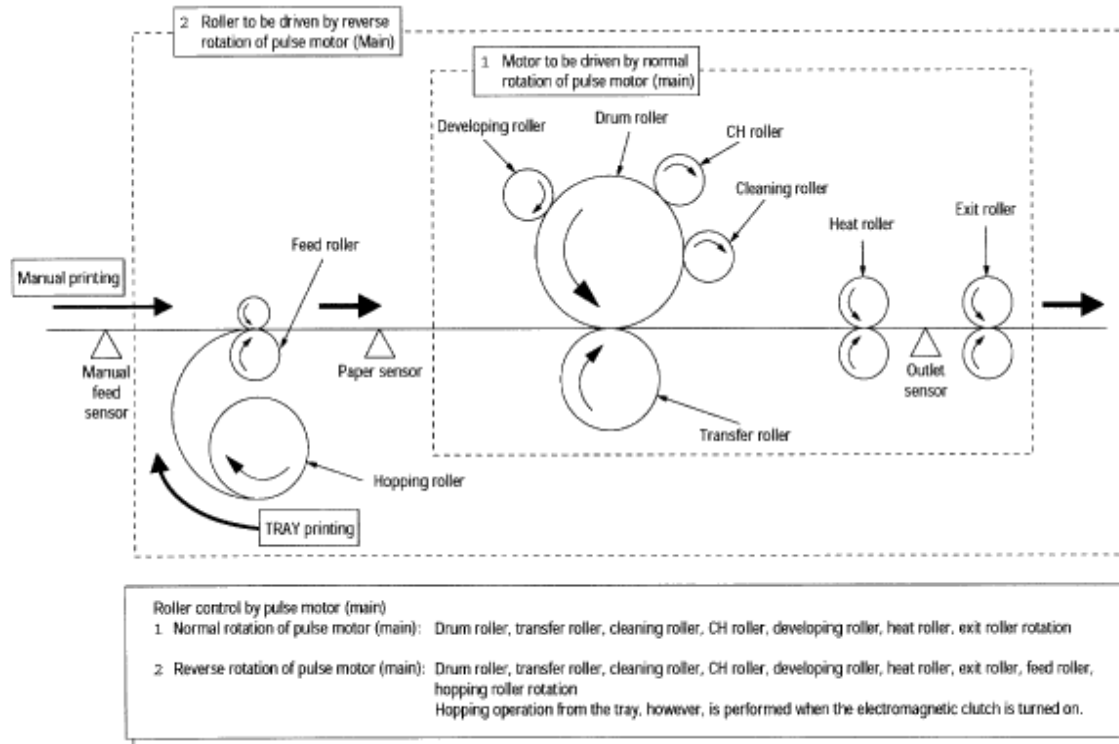

Figure 2-4 Schematic Drawing of OKIPAGE 4w Paper Feeding



Service Guide OKIPAGE4w

Chapter 2 Operation Description

Electro-Photographic Process

(1) Electro-photographic process

The electro-photographic process is outlined below.

1 Charging

The surface of the image drum is given a uniform negative charge by applying DC voltage to the CH roller.

2 Exposure

Light emitted from the LED head illuminates the negatively charged surface of the image drum. The surface potential of the lighted surface attenuates to form the electrostatic latent image corresponding to the image signal.

3 Development and residual toner recovery

The negatively charged toner is brought into contact with the image drum, adhering to the electrostatic latent image on the image drum by static electricity. This adhesion causes the electrostatic latent image to change to a visible image.

At the same time, the residual toner on the image drum is attracted to the developing roller by static electricity.

4 Transfer

When paper is placed over the image drum surface, the transfer roller applies a positive charge--which is opposite in polarity to that of the toner--to the reverse side. The toner is attracted by the positive charge and transfers the toner image from the image drum onto the paper.

5 Cleaning

The cleaning roller temporarily attracts the residual toner on the transferred image drum with static electricity, then returns the toner to the image drum.

6 Fusing

The transferred toner image is fused to the paper by applying heat and pressure .
Figure 2-5 is a flow diagram of the electro-photographic process.

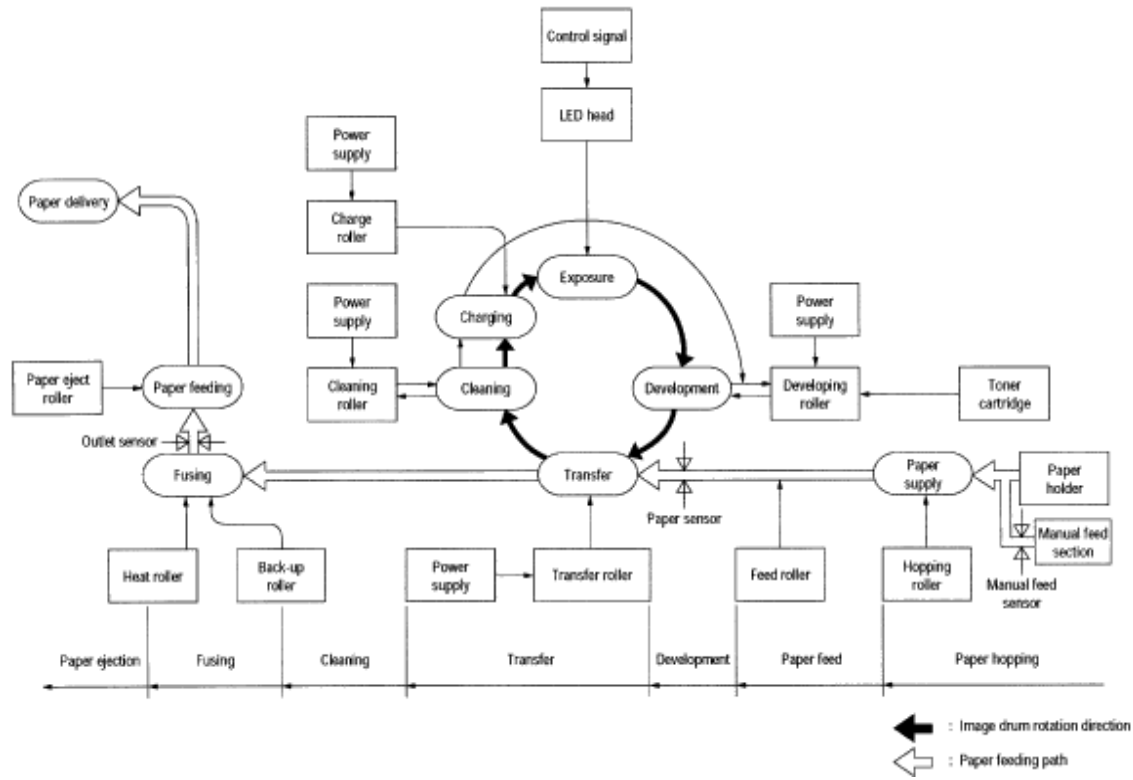

Copyright 1997, Okidata, Division of OKI America, Inc. All rights reserved. See the OKIDATA Business Partner Exchange (BPX) for any updates to this material. (<http://bpx.okidata.com>)

Explanation of Each Operation

(1) Hopping

As shown in the figure below, the clutch for hopping is turned on/off according to whether current to the coil is on or off.

When the clutch is OFF

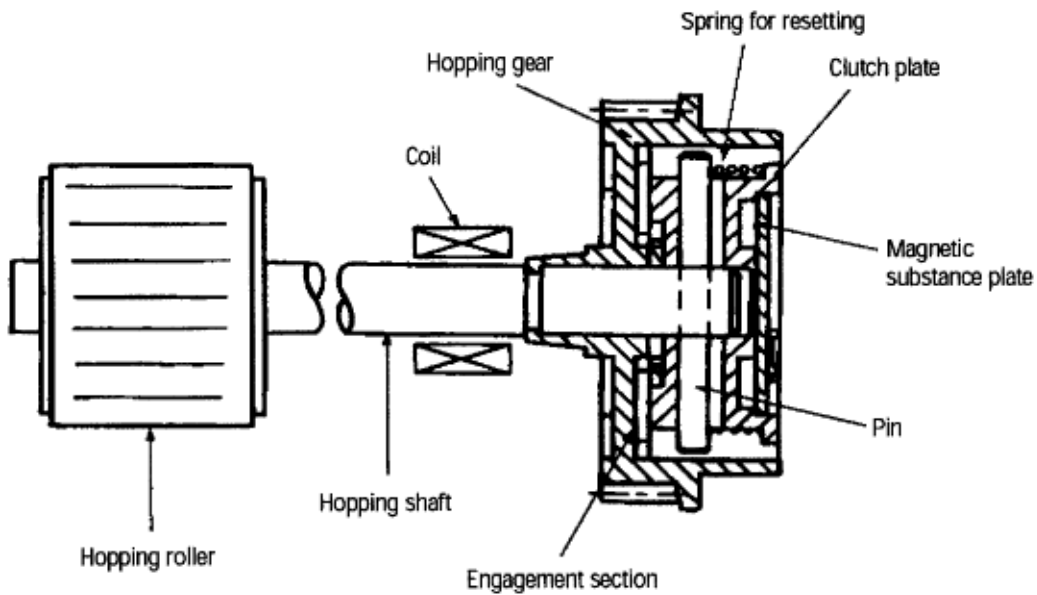

When the clutch is ON

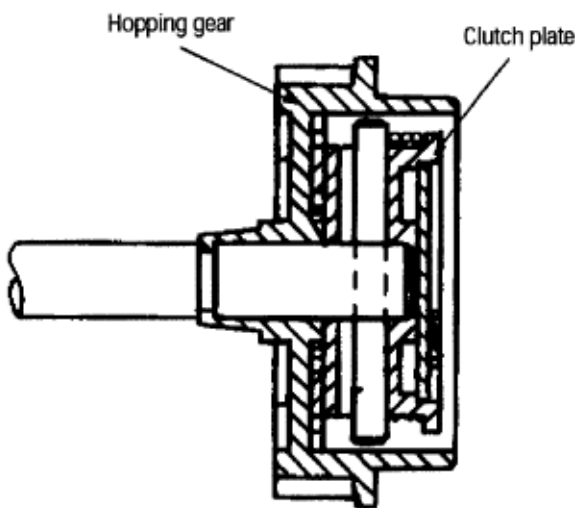

When the clutch is on, the hopping gear engages with the clutch plate to turn the hopping roller. When the clutch is off, the hopping gear is separated from the clutch plate by the spring for resetting, so that the hopping roller does not turn.

Copyright 1997, Okidata, Division of OKI America, Inc. All rights reserved. See the OKIDATA Business Partner Exchange (BPX) for any updates to this material. (<http://bpx.okidata.com>)

Printing and warm-up

At warm-up

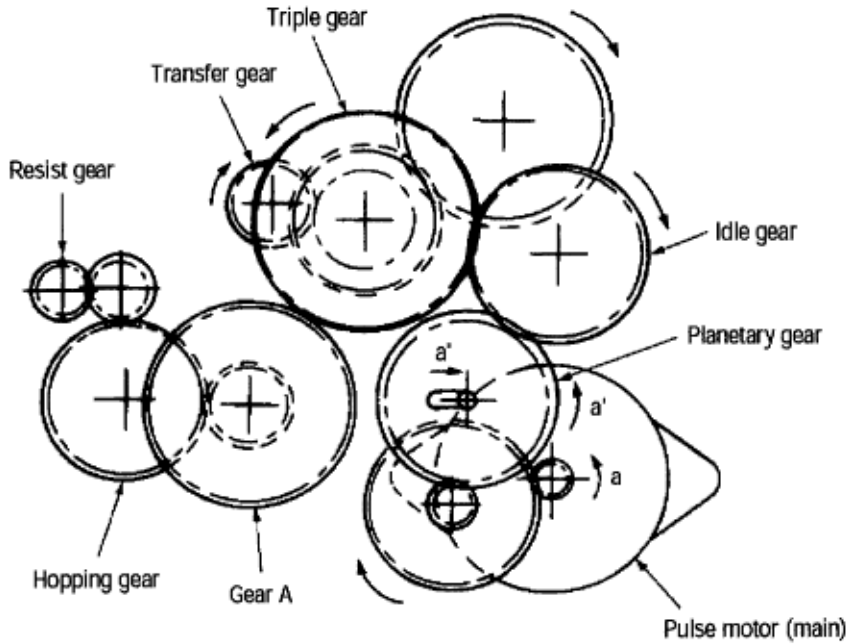

Rotate the pulse motor (main) in direction a. The planetary gear rotates in direction a', dislocating its position in direction a". This causes the planetary gear to be separated from gear A. The hopping gear will not rotate. The triple gear and transfer gear rotate via the idle gear to drive the image drum unit.
At printing

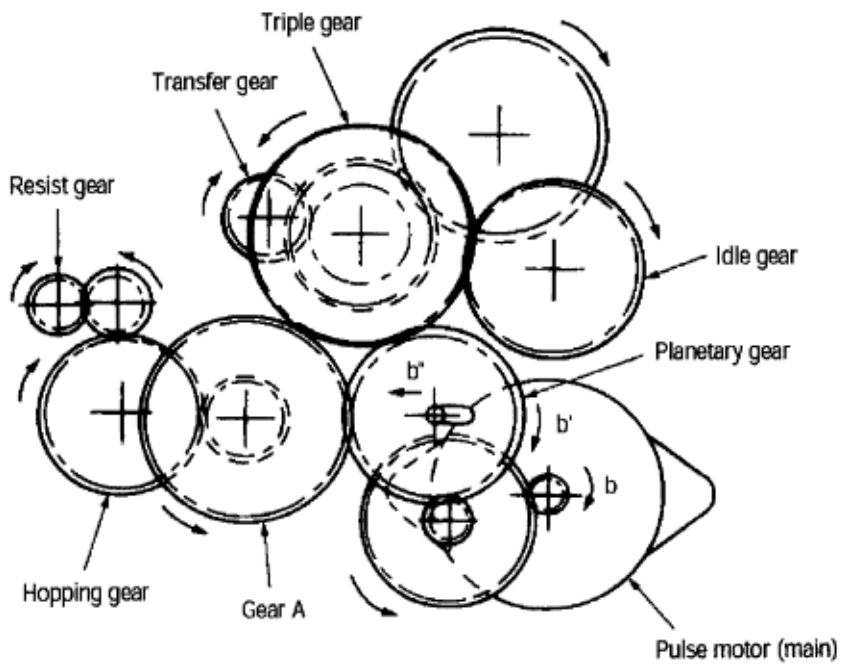

The paper advances further in synchronization with the print data.

Copyright 1997, Okidata, Division of OKI America, Inc. All rights reserved. See the OKIDATA Business Partner Exchange (BPX) for any updates to this material. (<http://bpx.okidata.com>)

Charging

Charging is performed by applying DC voltage to the charge roller in contact with the surface of the image drum.

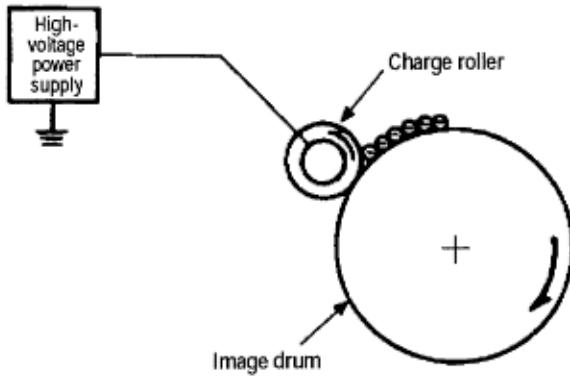

Copyright 1997, Okidata, Division of OKI America, Inc. All rights reserved. See the OKIDATA Business Partner Exchange (BPX) for any updates to this material. (<http://bpx.okidata.com>)

Exposure

Light emitted from the LED head irradiates the negatively charged surface of the image drum. The surface potential of the irradiated surface attenuates to form the electrostatic latent image corresponding to the image signal.

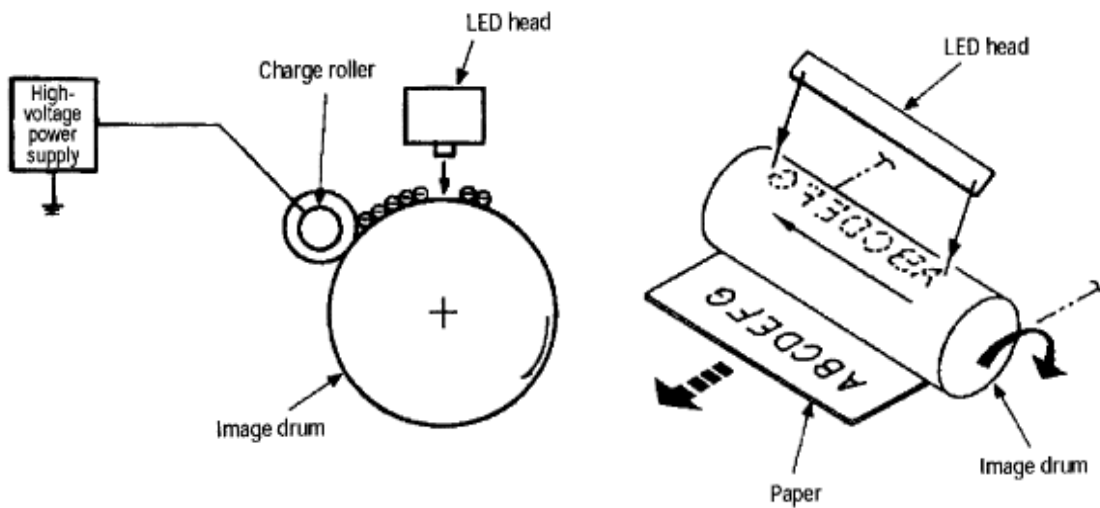

Development

Toner is attracted to the electrostatic latent image on the image drum surface, converting it into a visible toner image. Developing occurs through contact between the image drum and the developing roller.

1 As the toner supply roller rotates while rubbing on the developing roller, a friction charge is generated between the developing roller and the toner, attracting the toner to the developing roller. (The developing roller surface has a positive charge, while the toner has a negative charge.)

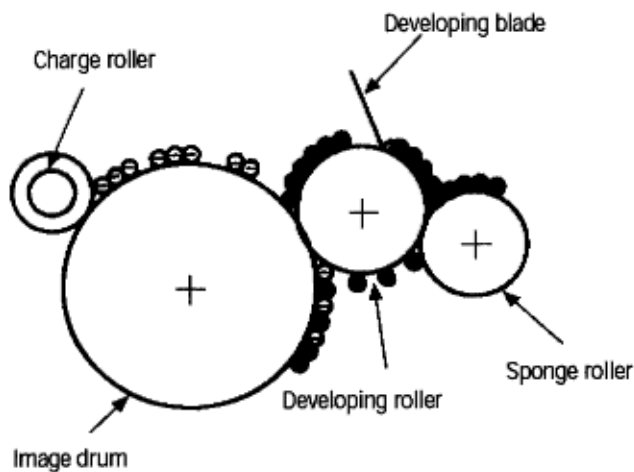

2 The toner attracted to the developing roller is scraped off by the developing blade, forming a thin coat of toner on the developing roller surface.

3 Toner is attracted to the exposed (low-potential) portion of the image drum at the point of contact between the image drum and the developing roller, making the electrostatic latent image visible.

Transfer

The transfer roller is composed of conductive sponge material. It is designed to bring the image drum and the paper into close contact.

A sheet of paper is placed over the image drum surface, and a positive charge, opposite to that of the toner, is applied to the paper from the reverse side.

High voltage from the power supply creates a positive charge on the surface of the transfer roller, which, in turn transfers the charge to the paper as it contacts the transfer roller. The image drum surface attracts the negatively charged toner, and the toner transfers to the paper as a result of the positive charge on the reverse side of the paper.

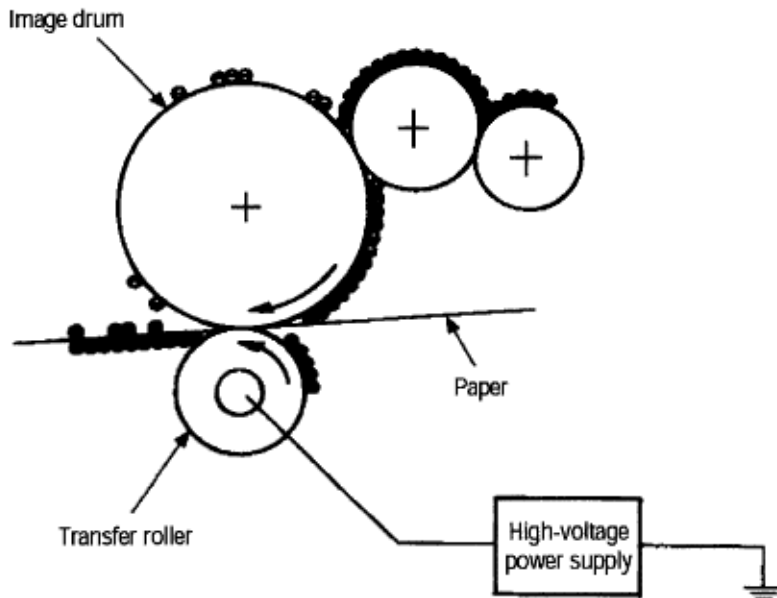

Fusing

The transferred toner image fuses to the paper, because heat and pressure are applied when it passes between the heat roller and back-up roller.

The Teflon-coated heat roller contains a 400 W heater (Halogen lamp) that heats the heat roller. The thermistor on the surface of the heat roller keeps its temperature constant. A thermostat is also installed for safety. If temperature rises abnormally, this thermostat opens to suspend voltage to the heater.

The back-up roller is pressed against the heat roller by the pressure spring on each side.

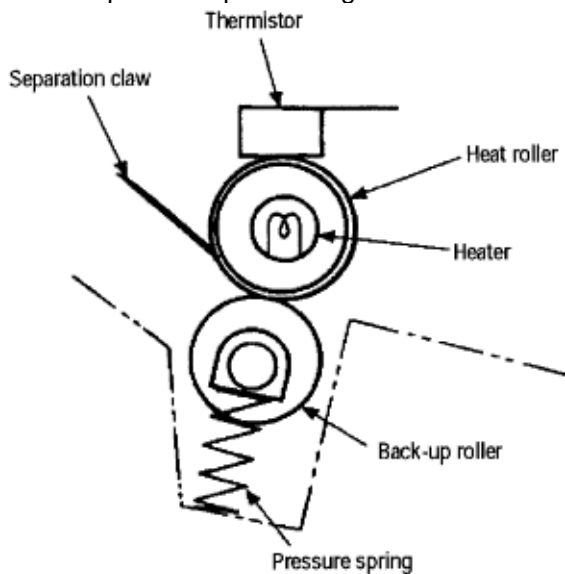

Cleaning

After transfer is complete, the cleaning roller temporarily draws in the residual toner adhering to the image drum with static electricity and then returns it to the image drum.

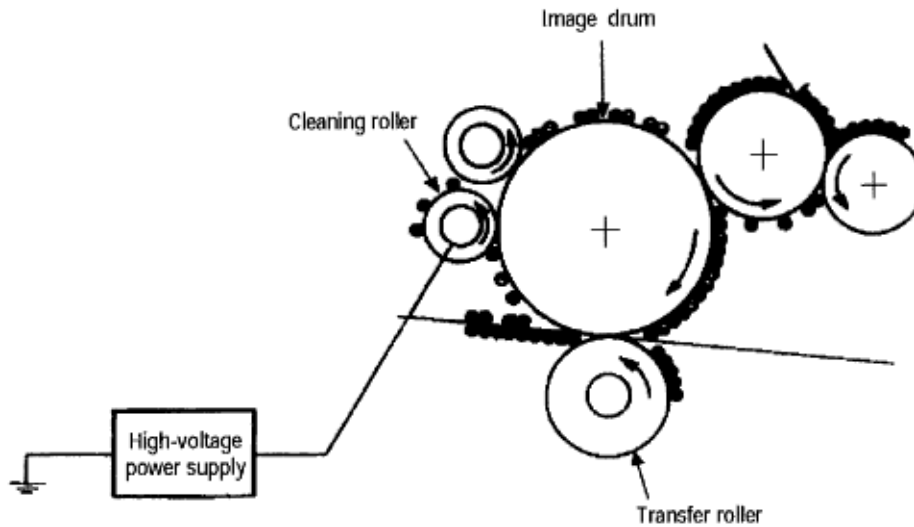



Service Guide OKIPAGE4w

Chapter 2 Operation Description

Paper Jam Detection

The OKIPAGE 4w monitors the paper status when the power supply is on and during printing. In the following cases, the OKIPAGE 4w interrupts the printing process and reports a paper jam. To resume printing, open the cover, remove the jammed paper, and close the cover.

Error	Cause of Error
Paper inlet jam	<ul style="list-style-type: none"> - Only the manual feed sensor detects "Paper exists" when the power supply is on. - The leading part of the paper does not reach the paper sensor although hopping operation was performed three time.
Paper feed jam	- The leading part of the paper does not reach the outlet sensor within a fixed time after it has passed the paper sensor.
Paper outlet jam	<ul style="list-style-type: none"> - The trailing part of the paper does not pass the outlet sensor within L mm after the leading part of the paper has passed the outlet sensor. <p>2.52" (64 mm) <= L <= 15.77" (400.6 mm)</p>
Paper size error	<ul style="list-style-type: none"> - The trailing part of the paper does not pass the paper sensor within L mm after the leading part of the paper has passed the paper sensor. <p>2.52" (64 mm) <= L <= 15.77" (400.6 mm)</p>

Paper Feed Check List

Type of Error	Supervisory Sensor	Reference Value	Error	
			Plus	Minus
Paper feed error	Electromagnetic clutch ON/Paper sensor ON	69.8	35	—
Paper feed jam 1	Paper sensor ON/ Outlet sensor ON	122.9	20.0	—
Paper size error	Paper sensor ON/ Paper sensor OFF	2.52" (64 mm) <= L <= 15.77" (400.56 mm)	—	—
Paper outlet jam	Outlet sensor ON/ Outlet sensor OFF	2.52" (64 mm) <= L <= 15.77" (400.56 mm)	45.0	45.0

Paper feed jam 2	Outlet sensor OFF/ Outlet sensor OFF	121.9	20.0	20.0
------------------	---	-------	------	------

Unit: mm

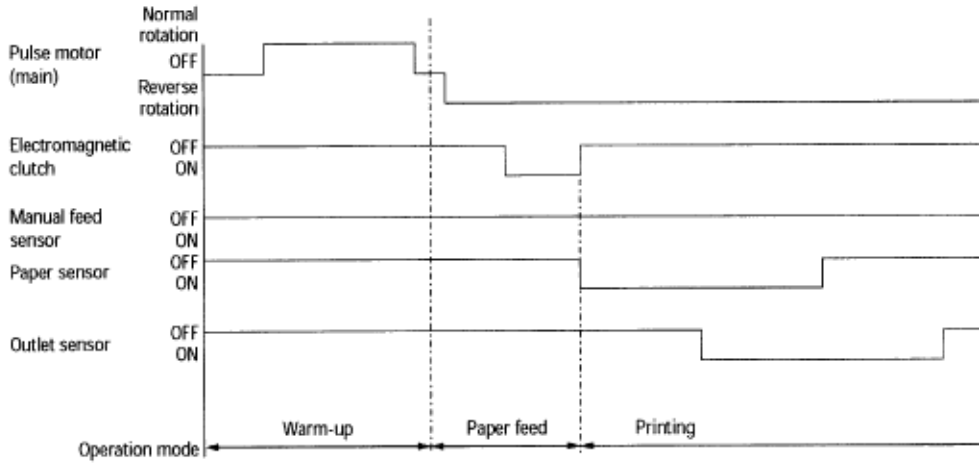

Timing Chart for Paper Feed (Tray Feed)

Copyright 1997, Okidata, Division of OKI America, Inc. All rights reserved. See the OKIDATA Business Partner Exchange (BPX) for any updates to this material. (<http://bpx.okidata.com>)

Toner Low Detection

- Hardware configuration of toner sensor

The figure below shows the hardware configuration of the toner sensor.

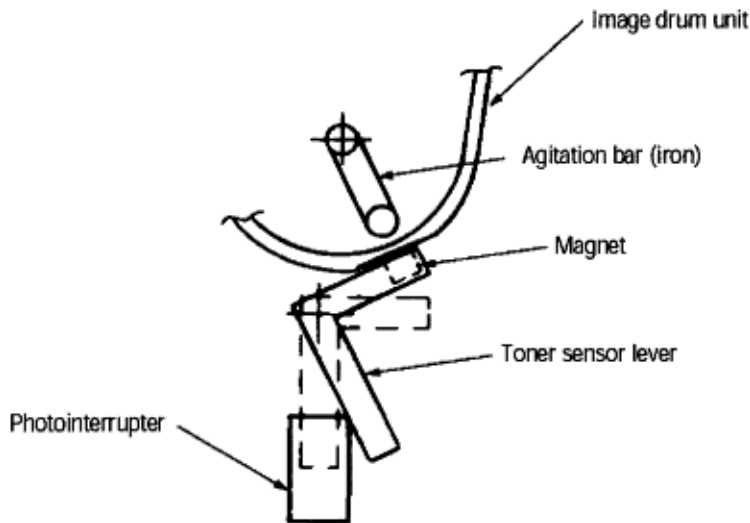

Hardware Configuration of Toner Sensor

- Toner detection method

(1) Toner sensor monitoring conditions are shown in the figure below.

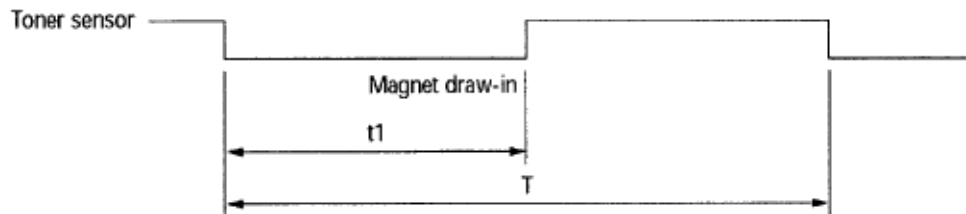

The toner sensor is not monitored when the drum is inactive.

- (a) When the toner-low state is detected twice, Toner Low occurs. (This state is monitored at a cycle of 40 milliseconds.)
- (b) When the toner-full state is detected twice, Toner Low is released. (This state is monitored at a cycle of 40 milliseconds.)
- (c) When the toner sensor does not change over two cycles ($T \times 2$), the toner sensor alarm state occurs.

(d) After the image drum unit has been replaced (after the drum counter has been reset), Toner Low is not detected until drum counter indicates 100.

(2) The basic rotation cycle of the toner sensor is as follows:

	T time
Basic rotation cycle of toner sensor	4.9 sec.
Toner low time	t1 > 1.2 sec.
Toner full time	1.2 sec. > t1 >

Copyright 1997, Okidata, Division of OKI America, Inc. All rights reserved. See the OKIDATA Business Partner Exchange (BPX) for any updates to this material. (<http://bpx.okidata.com>)



Service Guide OKIPAGE4w

Chapter 2 Operation Description

Cover Open

Opening the stacker cover turns off the microswitch on the high-voltage power supply board to suspend +5 V supply to the high voltage power supply. This stops all high-voltage outputs. At the same time, the CVOPN signal is issued to notify the main control board of the switch status and cover open processing is executed.

Copyright 1997, Okidata, Division of OKI America, Inc. All rights reserved. See the OKIDATA Business Partner Exchange (BPX) for any updates to this material. (<http://bpx.okidata.com>)



Service Guide OKIPAGE4w

Chapter 3 Parts Replacement

PARTS REPLACEMENT

This chapter explains how to replace parts, assemblies, and units in the field.

The replacement procedures to be explained here include disassembling, not assembling. When reassembling parts, assemblies, and units, reverse the disassembling steps.

Copyright 1997, Okidata, Division of OKI America, Inc. All rights reserved. See the OKIDATA Business Partner Exchange (BPX) for any updates to this material. (<http://bpx.okidata.com>)

Precautions for Parts Replacement

(1) Be sure to disconnect the AC cord and interface cable before replacing parts.

(a) Be sure to disconnect the AC cord in the following procedures:

- i) Turn off the POWER switch (O).
- ii) Disconnect the AC plug from the power outlet.
- iii) Disconnect the AC cord and interface cable from the printer.

(b) Be sure to reconnect the printer using the following procedures:

- i) Connect the AC cord and interface cable to the printer.
- ii) Connect the AC cord to the power outlet.
- iii) Turn on the printer's POWER switch (I).

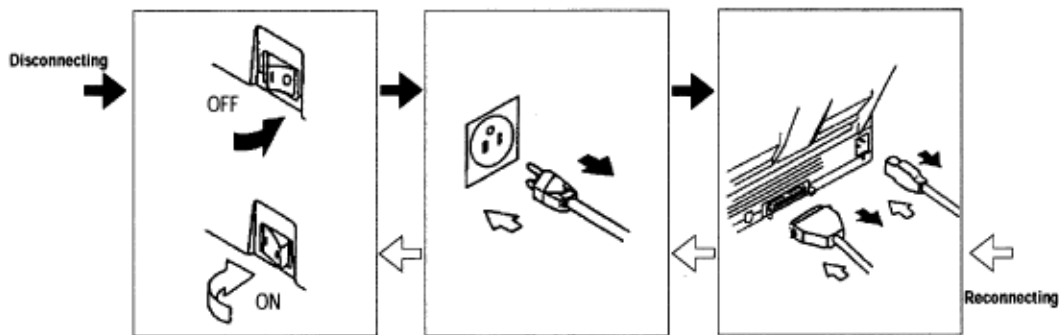

(2) Do not disassemble parts as long as the printer is operating normally.

(3) Minimize disassembling. (Only the parts indicated in the parts replacement procedures can be disassembled.)

(4) Use only the specified maintenance tools.

(5) Disassemble parts in the specified sequence; otherwise, parts may be damaged.







(6) Temporarily tighten small parts such as screws and collars to the original locations because they tend to be lost easily.

(7) When handling ICs such as CPUs, ROM, and RAM and PC boards, do not wear gloves that can generate static electricity.

(8) Do not place PC boards directly on devices or floors.

[Maintenance Tools]

Table 3-1 lists the maintenance tools necessary for parts replacement.

No.	Maintenance Tools	Q'ty	Use	Remarks
1	 No. 1-100 Philips screwdriver	1	2~2.5 mm screw	
2	 No. 2-100 Philips screwdriver	1	3~5 mm screw	
3	 No. 3-100 Philips screwdriver	1		
4	 No. 5-200 screwdriver	1		
5	 Digital multimeter (tester)	1		
6	 Pliers	1		
7	 Handy cleaner	1		

[Maintenance Utility]

Table 3-2 Maintenance Utility

No.	Maintenance Utility	Q'ty	Use	Remarks
1	 Maintenance utility	1		

Parts Layout

This section explains the layout of main parts.

[Upper Cover Assy]

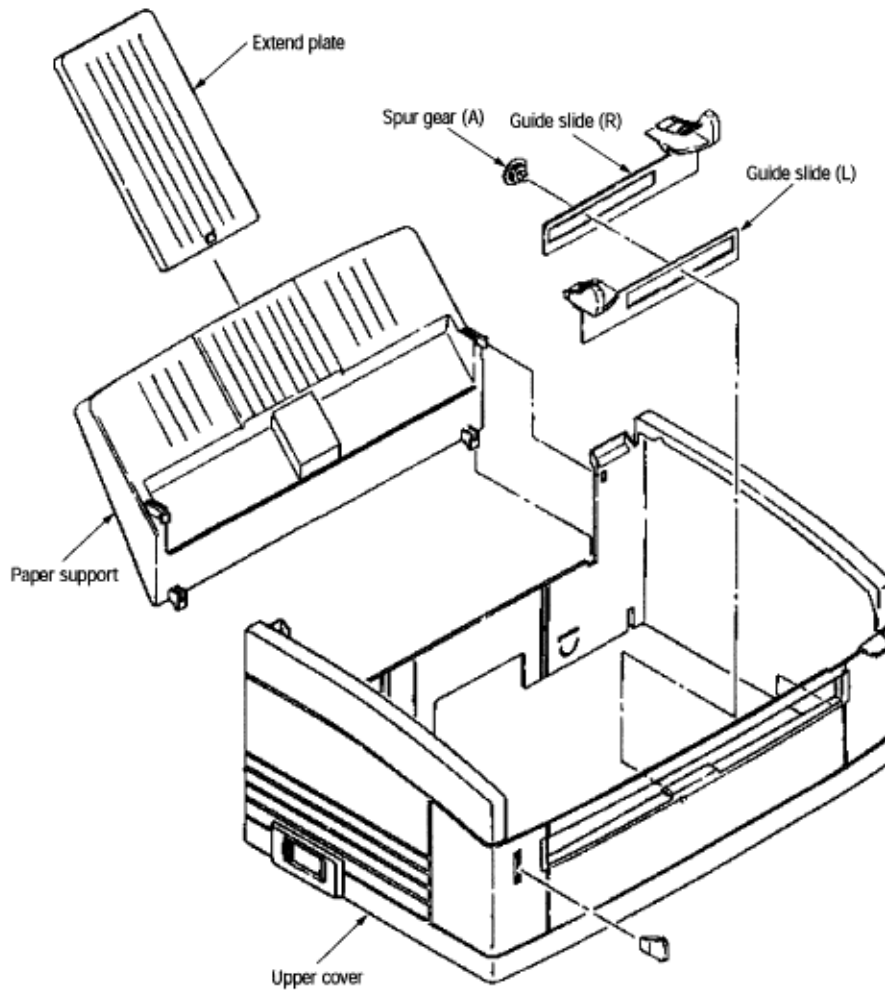
**Figure 3-1**

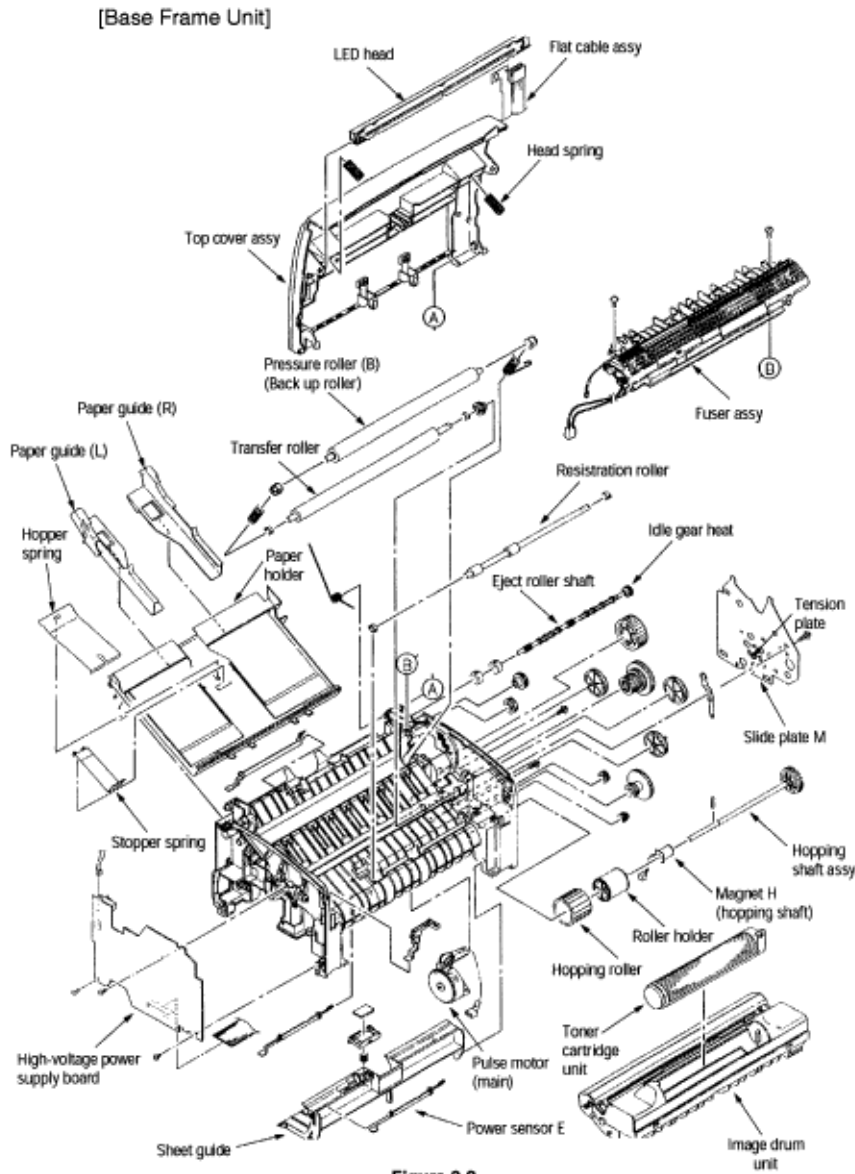

[Base Plate Unit]

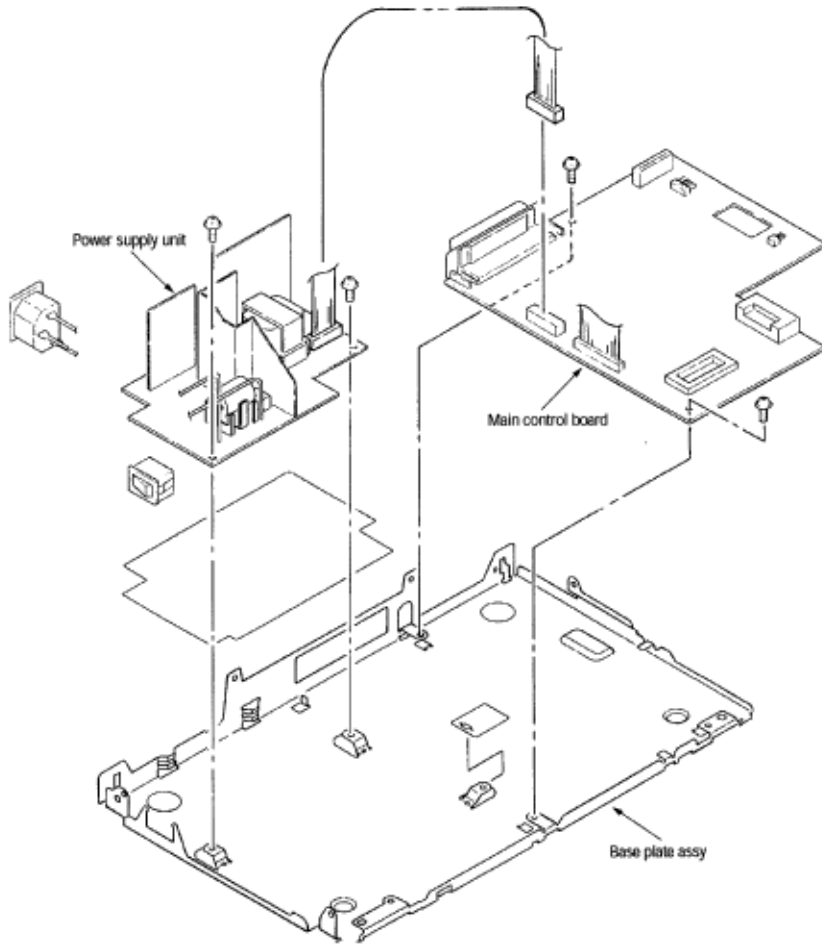

Figure 3-3



Service Guide OKIPAGE4w

Chapter 3 Parts Replacement

Replacing Parts

This section explains how to replace parts and assemblies.

Copyright 1997, Okidata, Division of OKI America, Inc. All rights reserved. See the OKIDATA Business Partner Exchange (BPX) for any updates to this material. (<http://bpx.okidata.com>)

Extend Plate

(1) Remove two claws and remove paper support assy 1.

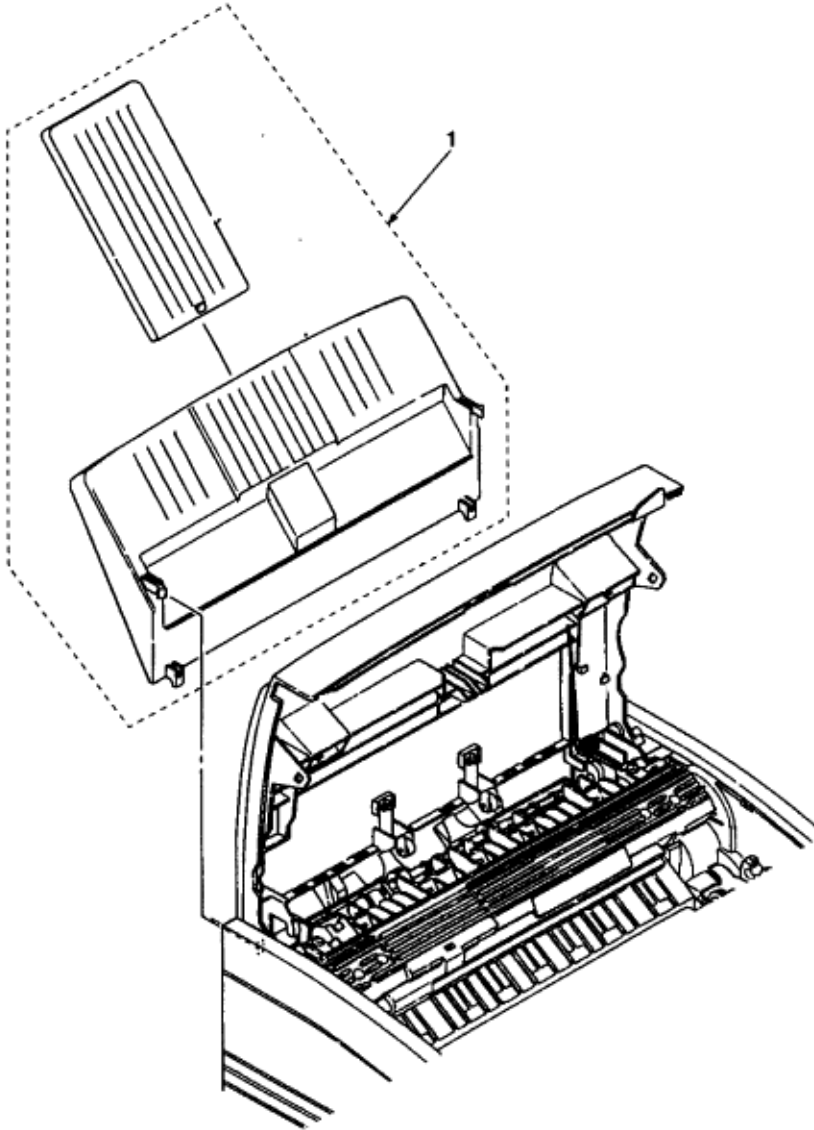

LED Head and Head Spring

- (1) Open top cover assy 1.
- (2) Remove the left clamp and LED head 2. Then remove flat cable assy 3 and FG cable 5.
- (3) Remove two head springs 4.

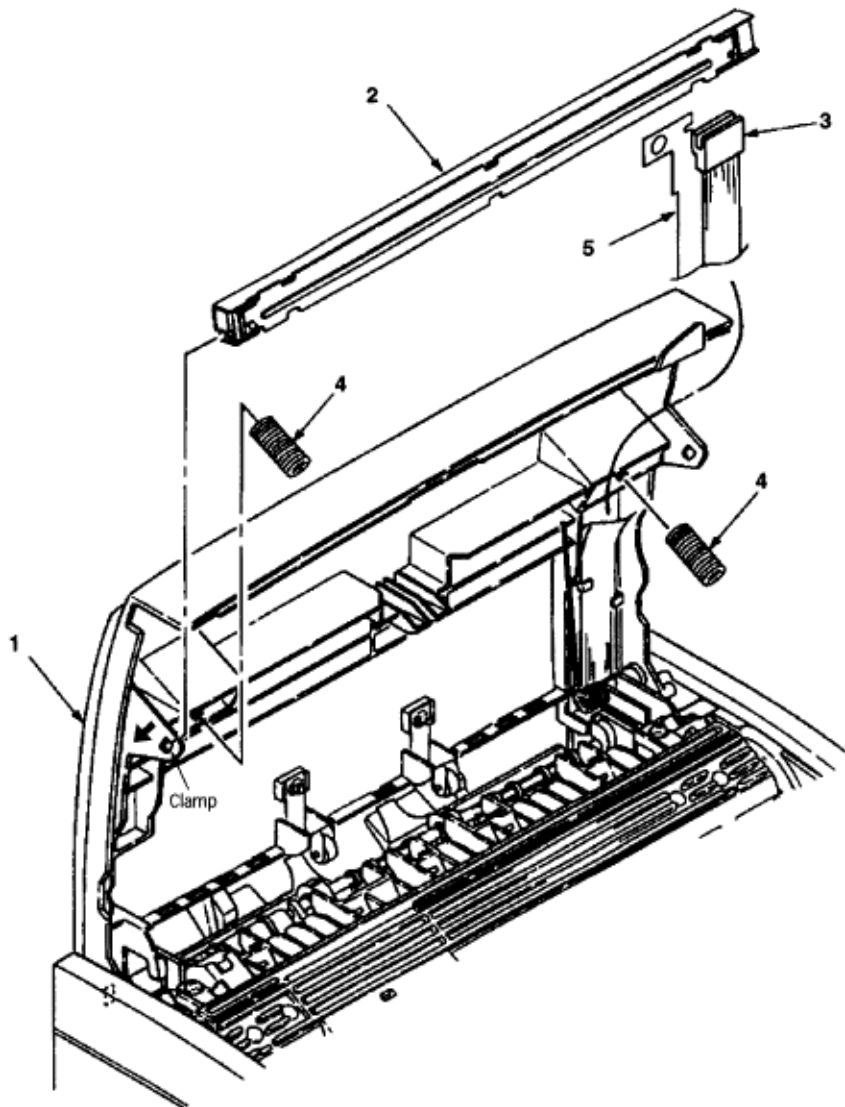

Transfer Roller

- (1) Open top cover assy **1** and remove image drum unit **2**.
- (2) Remove the right claw. Then remove transfer roller **3**, two registration bearings **4**, and gear **T5**.

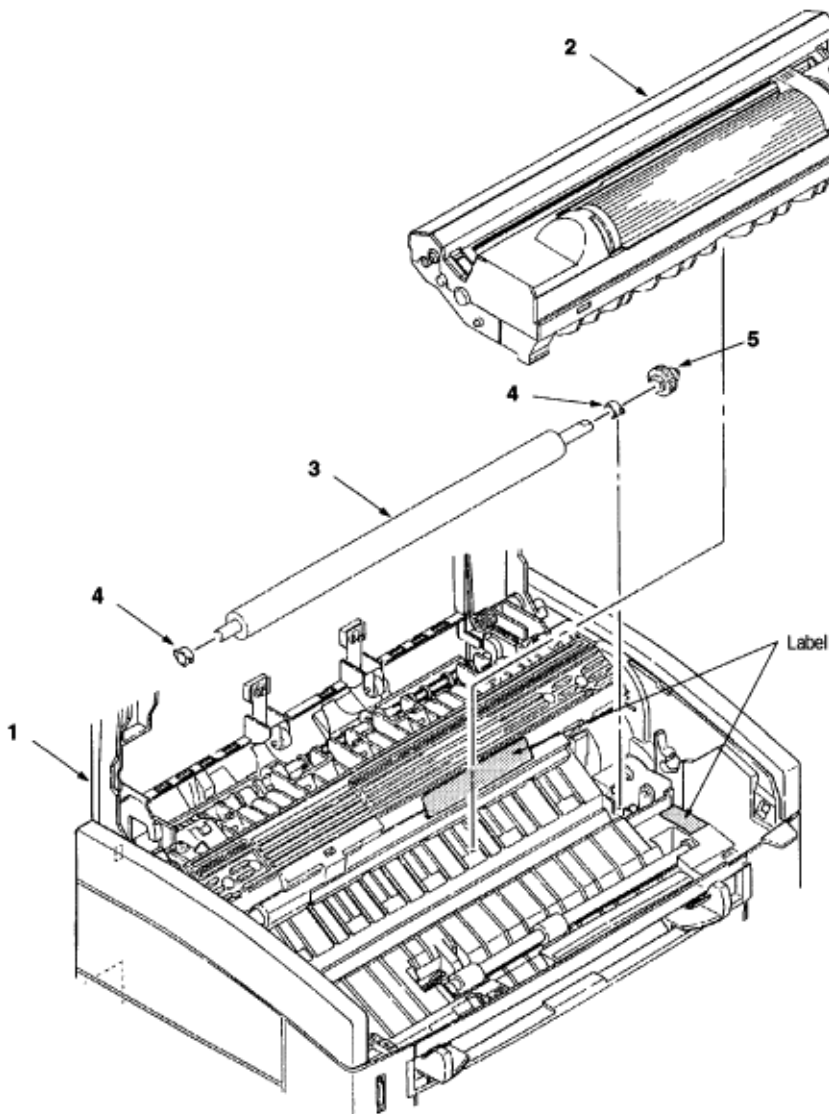

Upper Cover Assy

- (1) Turn off the power switch and unplug the AC cord from the AC socket.
- (2) Disconnect interface cable 1.
- (3) Open top cover assy 2 and remove image drum unit 3.
- (4) Move paper guide (L) 4 and paper guide (R) 5 on the rear of the printer to the center.
- (5) Remove two front claws of upper cover assy 6 and two rear screws A and lift upper cover assy 6.
- (6) Remove spur gear (A) 7, guide slide (L) 8, and guide slide (R) 9.
- (7) Remove lamp 10.

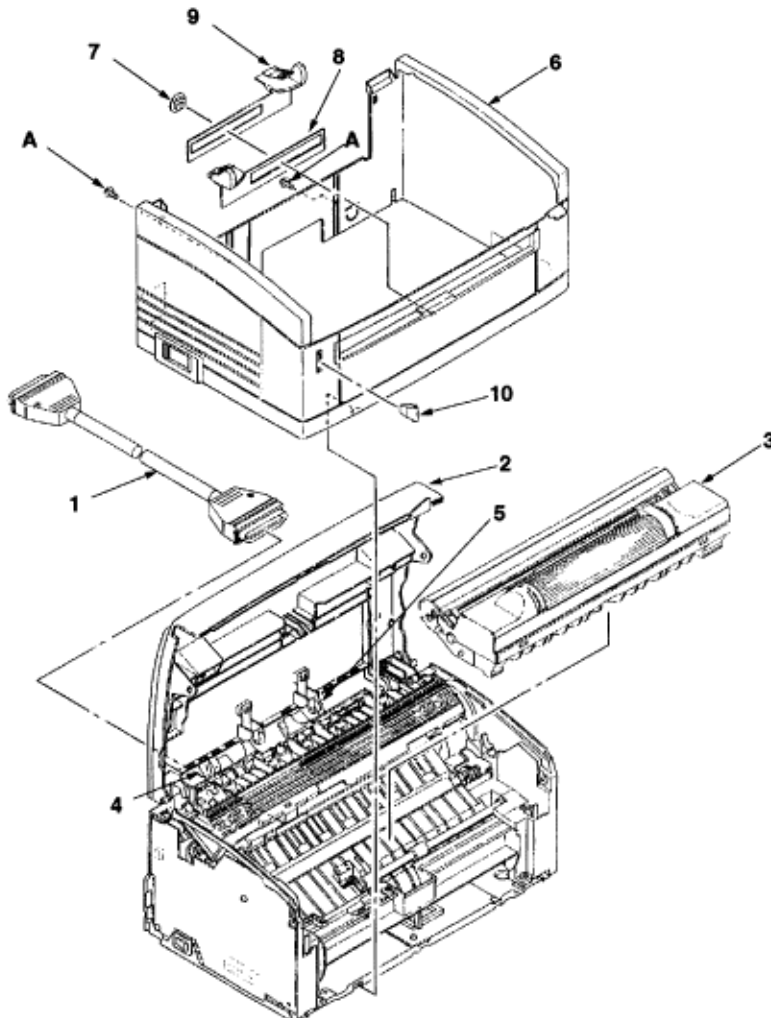

Copyright 1997, Okidata, Division of OKI America, Inc. All rights reserved. See the OKIDATA Business Partner Exchange (BPX) for any updates to this material. (<http://bpx.okidata.com>)

High-Voltage Power Supply Board

- (1) Remove upper cover assy. **(See Upper Cover Assembly in this Chapter).** 
- (2) Remove three screws **1** and draw out high-voltage power supply board **2**.
- (3) Disconnect all the cables **3** from high-voltage power supply board **2** and remove high-voltage power supply board **2**.

Caution: Note the following when assembling the high-voltage power supply board:

- Mount the high-voltage power supply board with top cover assy removed or open.
- Take care that cable **3** will not interfere with the paper sensor exit when it is connected.

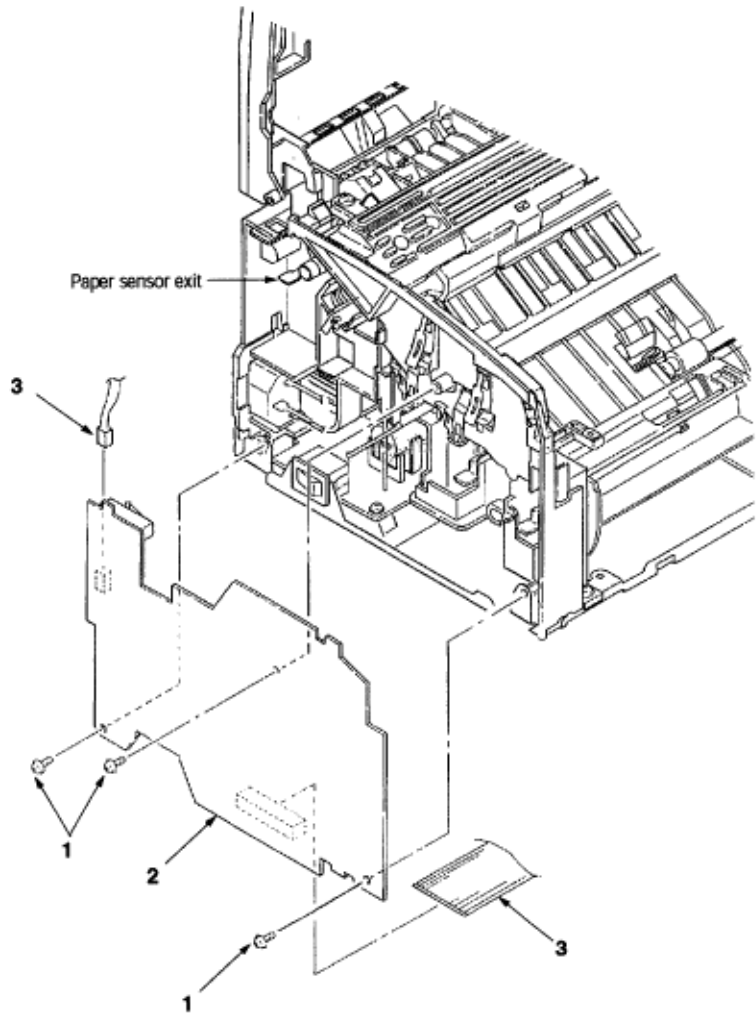

Copyright 1997, Okidata, Division of OKI America, Inc. All rights reserved. See the OKIDATA Business Partner Exchange (BPX) for any updates to this material. (<http://bpx.okidata.com>)

Top Cover Assy and Flat Cable Assy

- (1) Remove the upper cover assy. **(See Upper Cover Assembly in this Chapter).**
- (2) Remove the LED head. **(See LED Head and Head Spring in this Chapter).**
- (3) Press the left clamp outward and remove the engagement and top cover assy **1**. (Tension spring **2** also comes off at the same time.)
- (4) Disconnect connector CN6 and remove flat cable assy **3**.
- (5) Remove screw **5** and remove FG cable **4**.

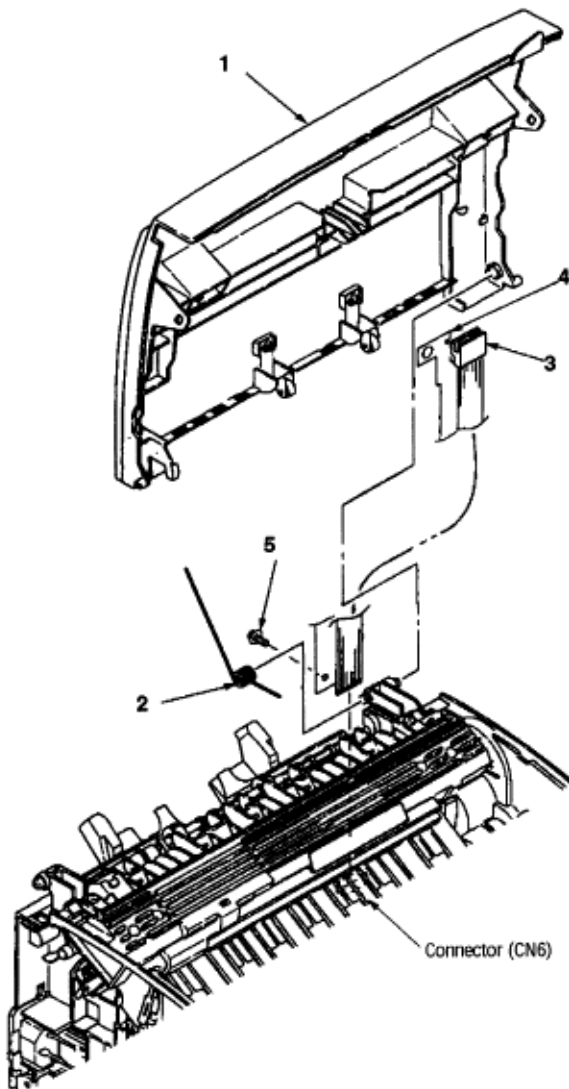

Copyright 1997, Okidata, Division of OKI America, Inc. All rights reserved. See the OKIDATA Business Partner Exchange (BPX) for any updates to this material. (<http://bpx.okidata.com>)

Paper Holder

- (1) Remove the upper cover assy. **(See Upper Cover Assembly in this Chapter).** 
- (2) Remove paper holder **1**.
- (3) Unlock and remove paper guide (L) **2** and paper guide (R) **3**.
- (4) Remove the claw and remove hopper spring **4**.
- (5) Remove the claw and remove stopper spring **5**.

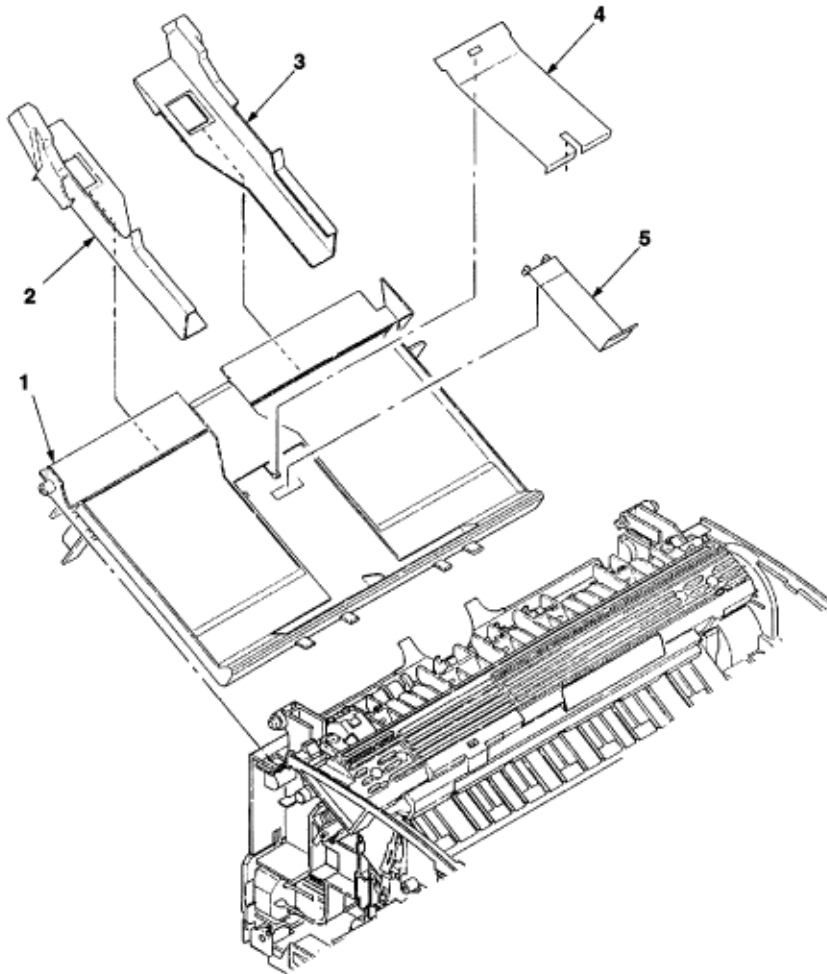

Side Plate M and Idle Gear

Perform parts replacement while making the base frame assy stand so that side plate M will face upward.

- (1) Remove the upper cover assy. **(See Upper Cover Assembly in this Chapter).**
- (2) Remove two screws **1** and two claws, then remove plate side **M2**.
- (3) Remove grounding plate **3**, two idle gears **P 4**, idle gear **M 5**, idle gear **3R 6**, idle gear **2R 7**, idle gear **heat 8**, idle gear **R 9**, and gear **R 10**.

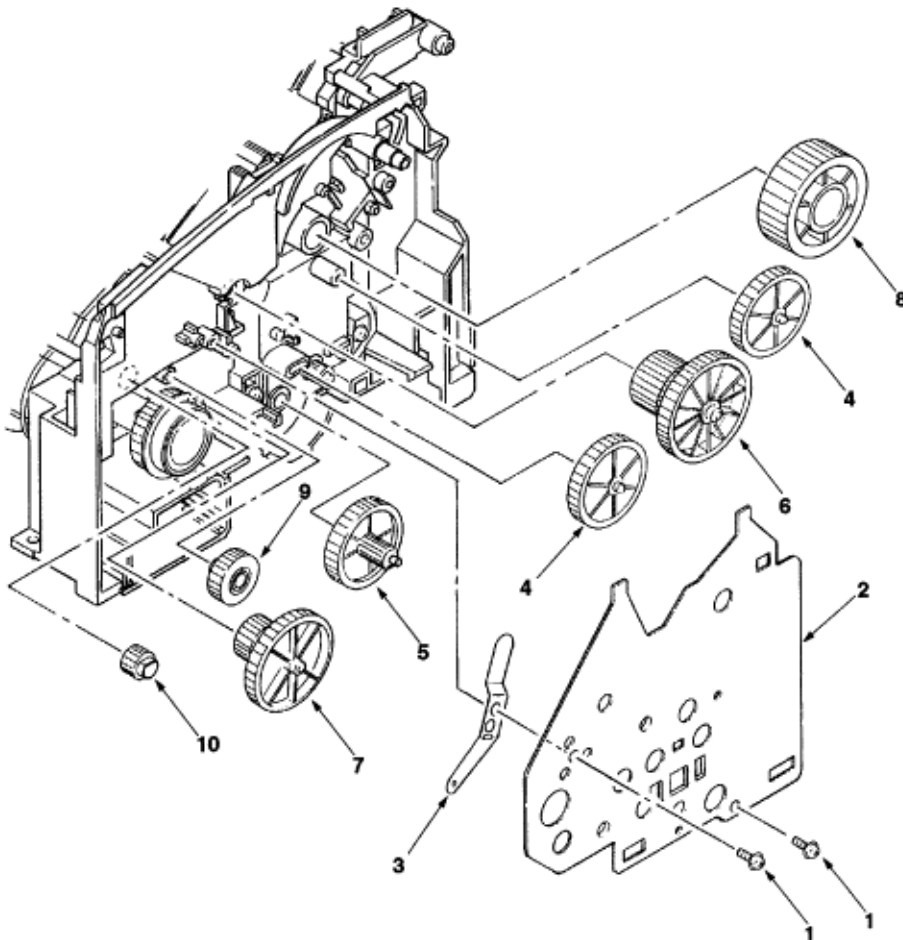



Registration Roller

(1) Remove the upper cover assy. (**See Upper Cover Assembly in this Chapter.**)

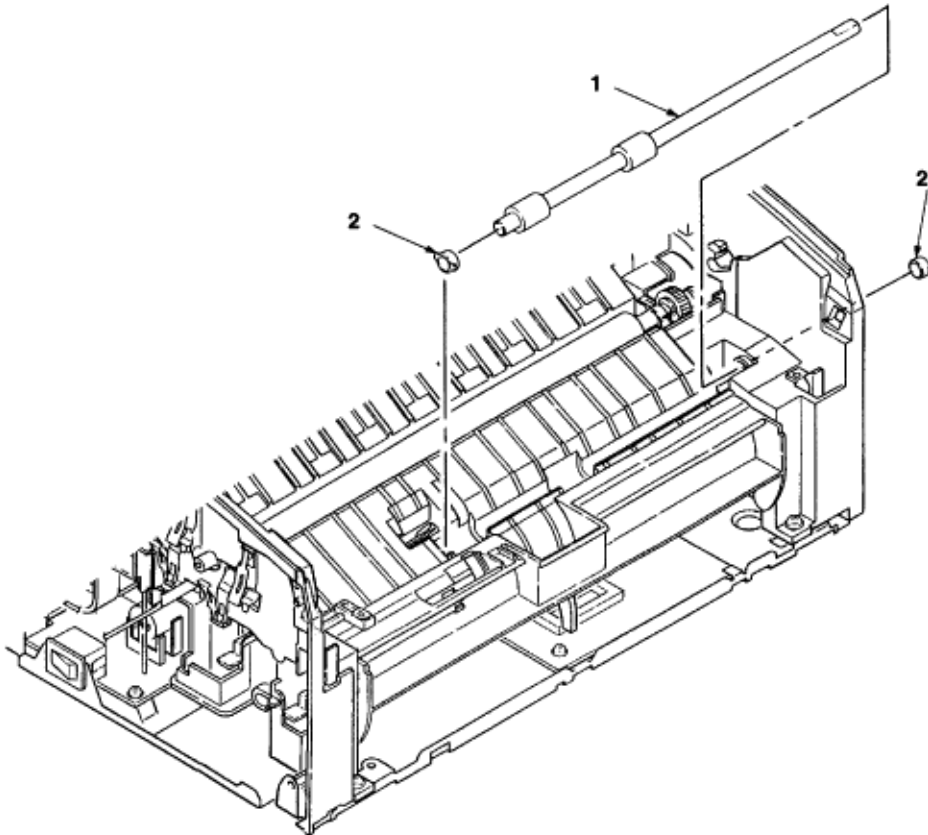
(2) Move registration roller **1** to the right and remove it by lifting. (Two registration bearings **2** also come off at the same time. Take care not to lose them.)



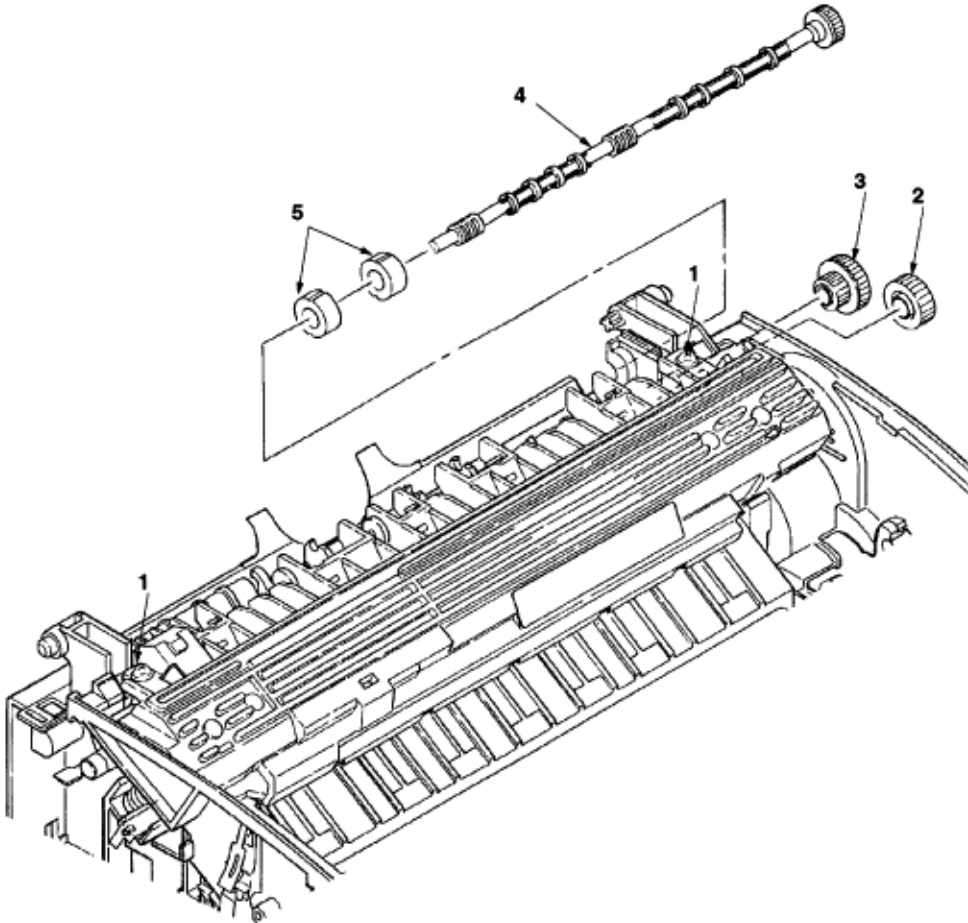

Eject Roller Shaft and Eject Roller

- (1) Remove the upper cover assy. **(See Upper Cover Assembly in this Chapter).** 
- (2) Remove top cover assy. **(See Top Cover Assy and Flat Cable Assy in this Chapter).** 
- (3) Remove two screws **1** from cover head assy (Section 3.3.11), lift the fuser assy, and remove idle gear E (A) **2** and idle gear E (B) **3**.
- (4) Unlock and remove eject roller shaft **4**.
- (5) Remove two eject rollers **5**.



Fuser Assy

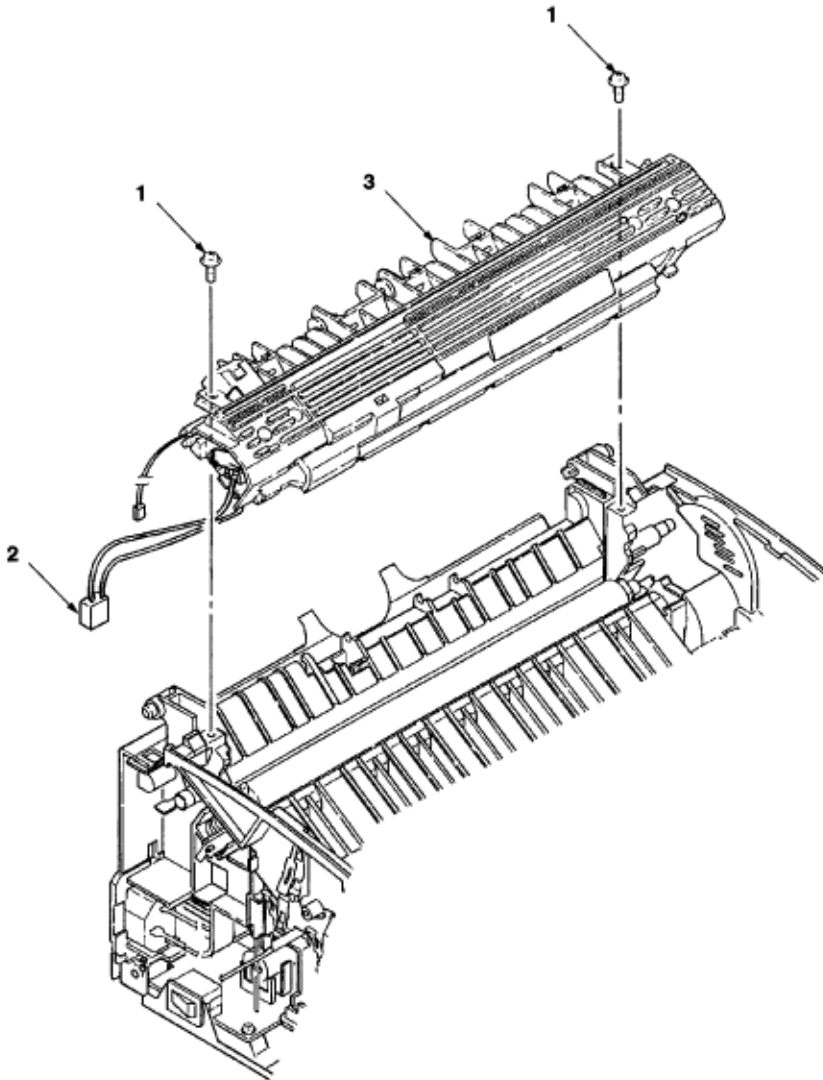

- (1) Remove the upper cover assy. **(See Upper Cover Assy in this Chapter).** 
- (2) Remove the high-voltage power supply board. **(See High-Voltage Power Supply Board in this Chapter).** 
- (3) Remove two screws **1**, disconnect connector **2**, and remove heat assy **3**.

Note: Do not disconnect lamp ground screw on left side of fuser.



Exchange (BPX) for any updates to this material. (<http://bpx.okidata.com>)

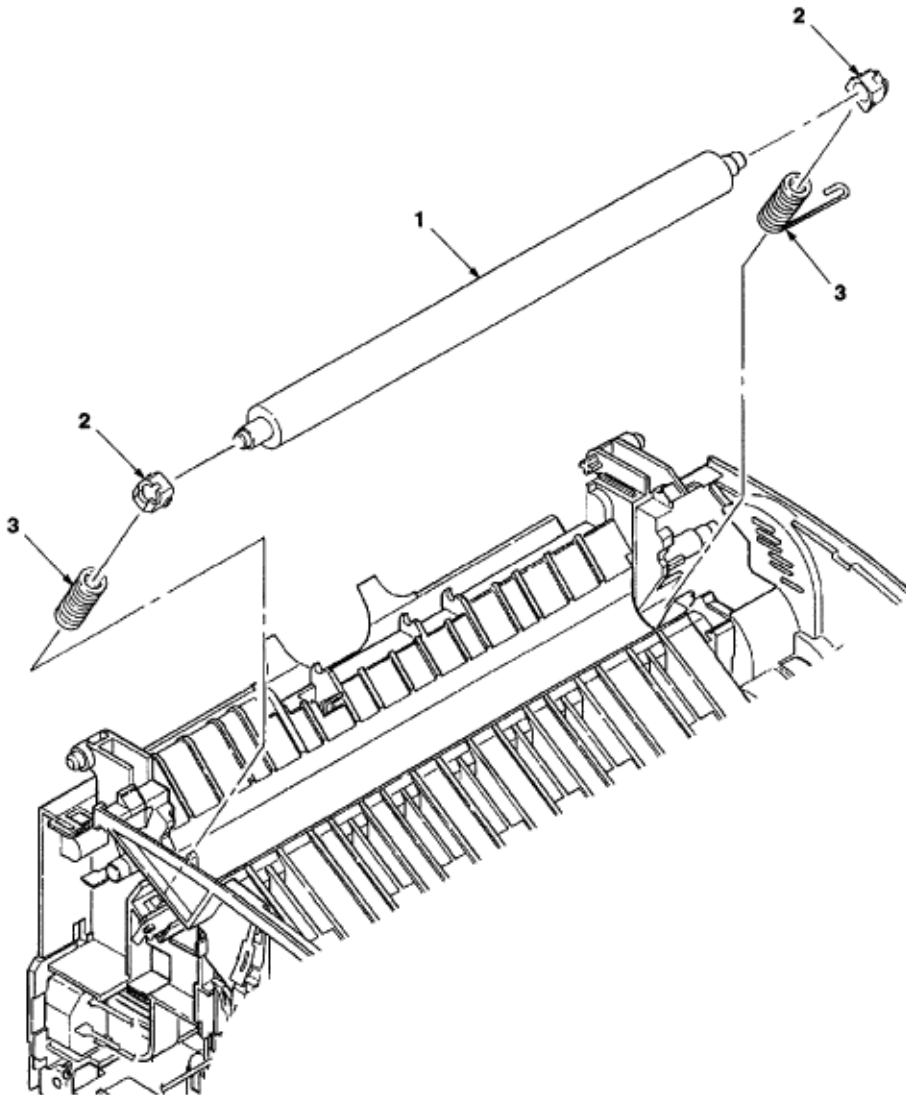

Pressure Roller B (Back Up Roller)

- (1) Remove the upper cover assy. **(See Upper Cover Assy in this Chapter).** 
- 2) Remove the high-voltage power supply board. **(See High-Voltage Power Supply Board in this Chapter).** 
- (3) Remove the fuser assy. **(See Fuser Assy in this Chapter).** 
- (4) Remove the engagement with the left ground, then pressure roller B1. (Two bearing BUs 2 and two bias springs 3 also come off at the same time.)



Copyright 1997, Okidata, Division of OKI America, Inc. All rights reserved. See the OKIDATA Business Partner Exchange (BPX) for any updates to this material. (<http://bpx.okidata.com>)

Separator Guide

- (1) Remove the upper cover assy. **(See Upper Cover Assy in this Chapter).** 
- (2) Remove the high-voltage power supply board. **(See High-Voltage Power Supply Board in this Chapter).** 
- (3) Remove five screws **1**.
- (4) Remove inlet **2** from base frame **3**.

Removing inlet 2

Insert a screwdriver into the hole on the side of base frame **3**, remove the inlet claw from base frame **8**, and remove inlet **2**.

- (5) Disconnect three cables **4** and connector **11** and remove base frame **3**. Then, remove screw **10** and disconnect FG cable **12**.

Disconnecting connector 11



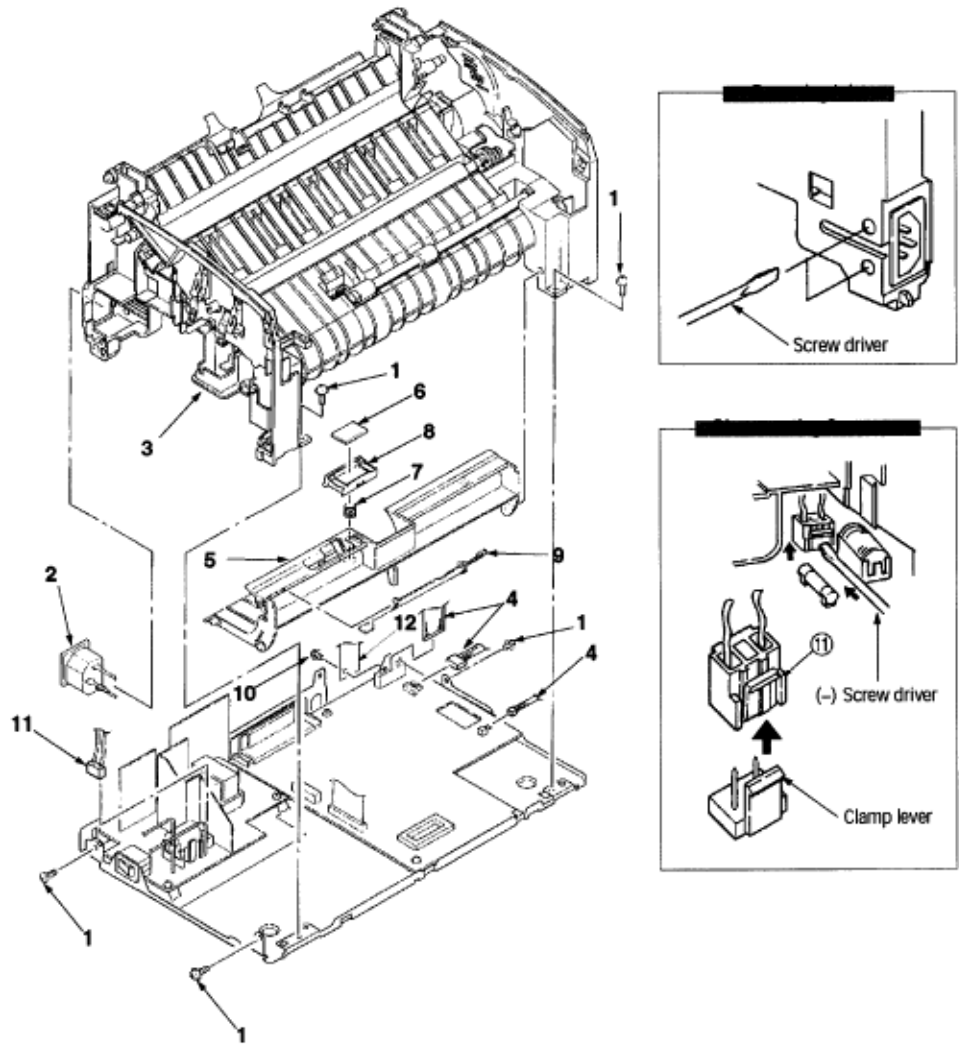

Remove connector **11** by drawing it upward while pushing the clamp lever with a standard screwdriver.

- (6) Remove the paper holder assy. **(See Paper Holder in this Chapter).** 
- (7) Remove two engagements and sheet guide **5**.
- (8) Remove friction pad **6**, compression spring **S7**, and separator guide **8**.
- (9) Remove paper sensor **E9**.



Copyright 1997, Okidata, Division of OKI America, Inc. All rights reserved. See the OKIDATA Business Partner Exchange (BPX) for any updates to this material. (<http://bpx.okidata.com>)

Pulse Motor (Main)

- (1) Remove the upper cover assy. **(See Upper Cover Assy in this Chapter).** 
- (2) Remove the high-voltage power supply board. **(See High-Voltage Power Supply Board in this Chapter).** 
- (3) Remove side plate M. **(See Side Plate M and Idle Gear in this Chapter).** 
- (4) Remove the base frame. **(See Separator Guide in this Chapter).** 
- (5) Remove two screws **1** and remove pulse motor (main) **2**.

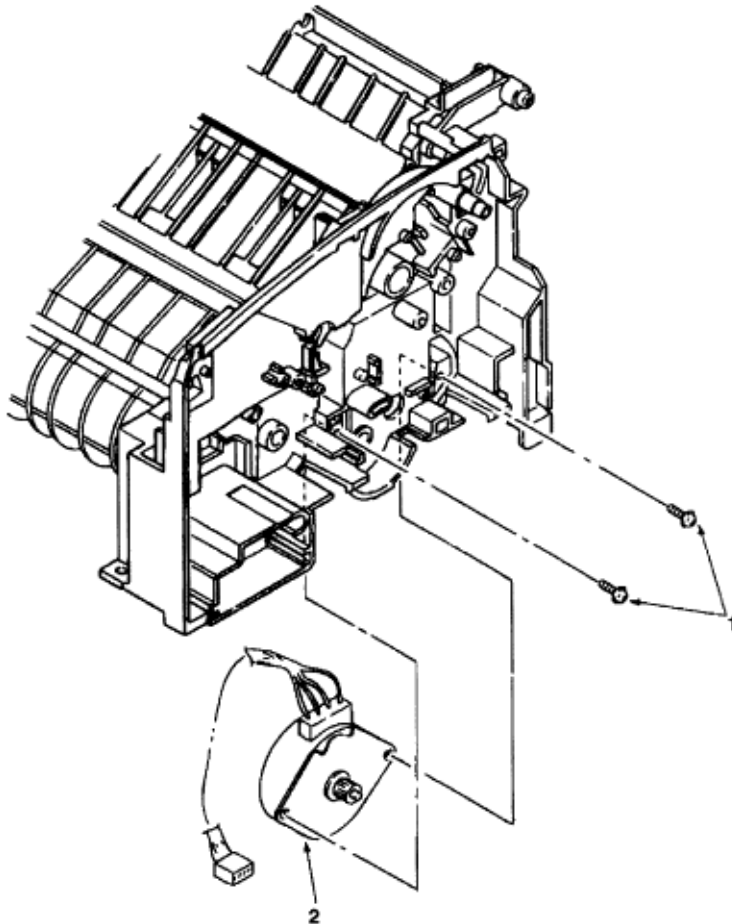





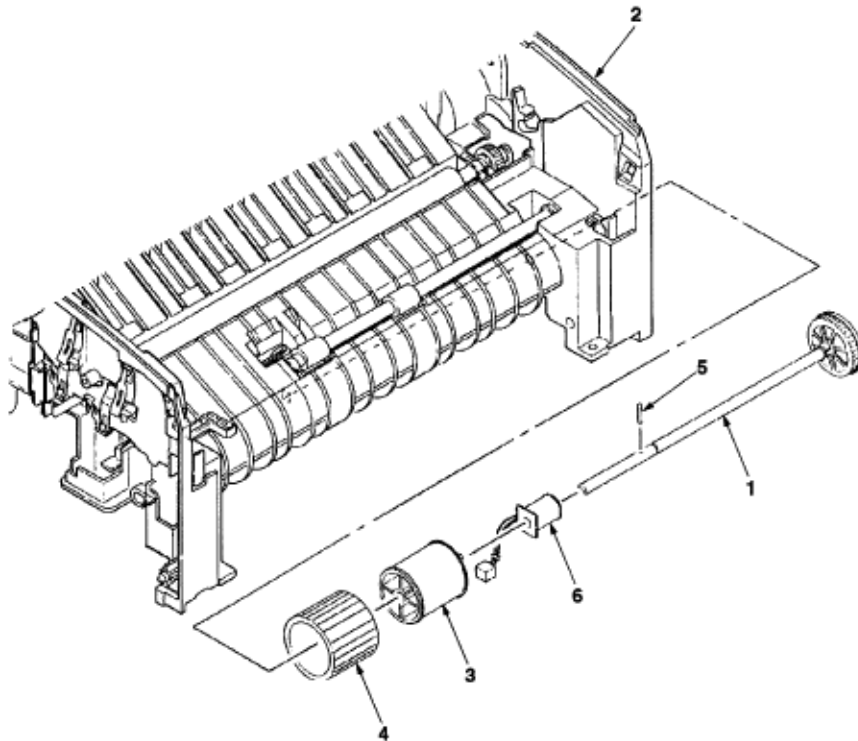

Hopping Shaft Assy

- (1) Remove the upper cover assy. **(See Upper Cover Assy in this Chapter).**
- (2) Remove the high-voltage power supply board. **(See High-Voltage Power Supply Board in this Chapter).**
- (3) Remove the base frame. **(See Separator Guide in this Chapter).**
- (4) Remove the paper holder assy. **(See Paper Holder in this Chapter).**
- (5) Remove the sheet guide. **(See Separator Guide in this Chapter).**
- (6) Remove side plate M. **(See Side Plate M and Idle Gear in this Chapter).**
- (7) Raise up roller holder **3**, slide hopping shaft assy **1**, and remove roller holder **3** and hopping roller **4**. (Knock pin **5** also comes off at the same time. Take care not to lose it.)
- (8) Draw out hopping shaft assy **1** to the right and remove magnet H6.



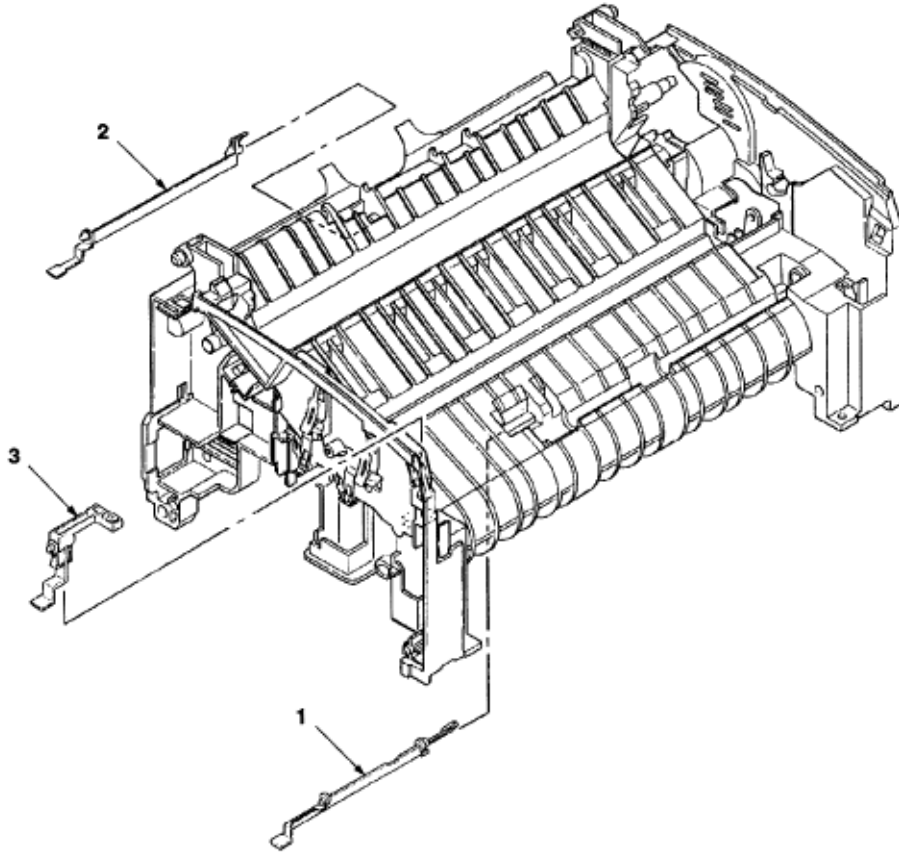

Paper Sensor E, Paper Sensor Exit and Toner Sensor Assy

- (1) Remove the upper cover assy. **(See Upper Cover Assy in this Chapter).** 
- (2) Remove the high-voltage power supply board. **(See High-Voltage Power Supply Board in this Chapter).** 
- (3) Remove the base frame. **(See Separator Guide).** 
- (4) Remove the paper holder assy. **(See Paper Holder in this Chapter).** 
- (5) Remove the sheet guide. **(See Separator Guide in this Chapter).** 
- (6) Remove the fuser assy. **(See Fuser Assembly in this Chapter)** 
- (7) Remove eject roller shaft. **(See Eject Roller Shaft and Eject Roller in this Chapter).** 
- (8) Remove paper sensor E1.
- (9) Remove paper sensor exit **2**.
- (10) Remove toner sensor assy **3**.



Copyright 1997, Okidata, Division of OKI America, Inc. All rights reserved. See the OKIDATA Business Partner Exchange (BPX) for any updates to this material. (<http://bpx.okidata.com>)

Base Plate

- (1) Remove the upper cover assy. **(See Upper Cover Assy in this Chapter).** 
- (2) Remove the base frame. **(See Separator Guide in this Chapter).** 
- (3) Remove two screws **1**, disconnect connector **2**, and remove power supply unit **3**.
- (4) Remove insulation sheet **4**.
- (5) Remove two screws **5** and remove main control board **6** from base plate **7**.

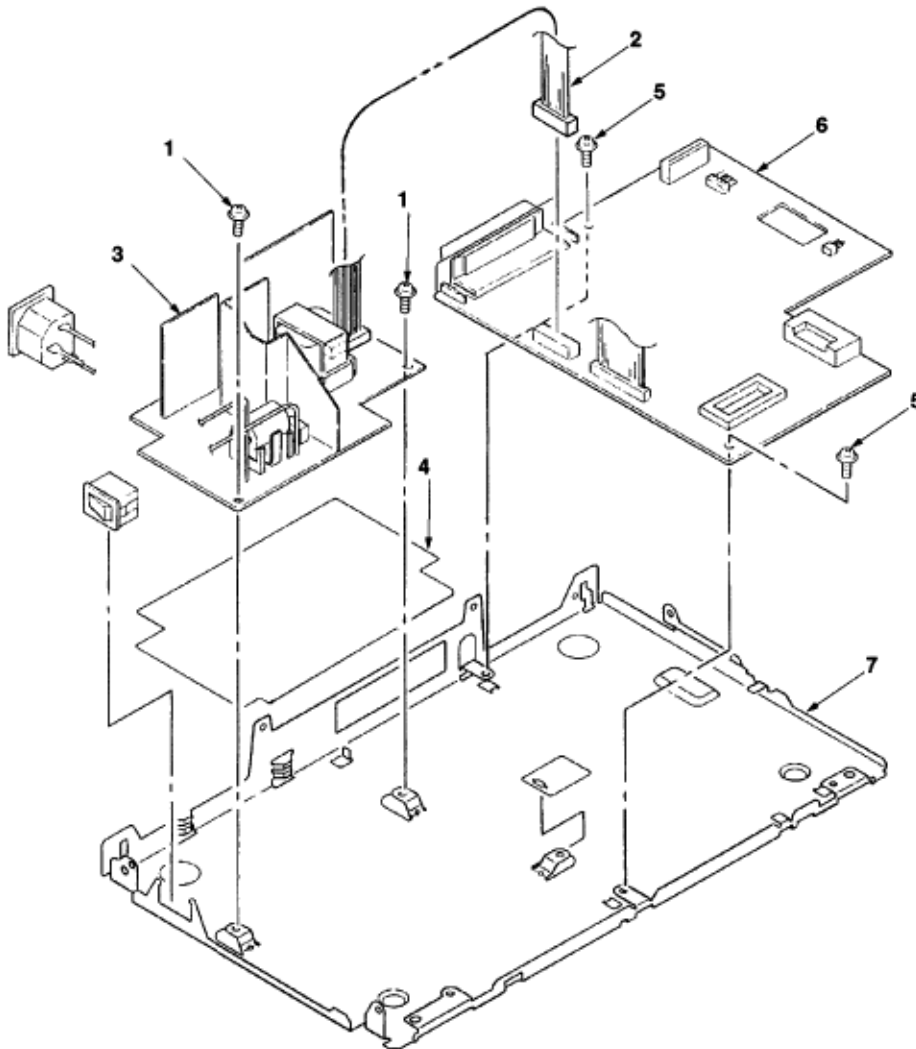

Exchange (BPX) for any updates to this material. (<http://bpx.okidata.com>)



Service Guide OKIPAGE4w

Chapter 4 Adjustment

ADJUSTMENT

This chapter explains adjustment necessary when a part is replaced.

This adjustment is made by changing the parameters values set in EEPROM on the main control board. The printer driver or maintenance utility can be used to change these values.

Only service and maintenance personnel may use the maintenance utility. This utility cannot be made public for end users.

Copyright 1997, Okidata, Division of OKI America, Inc. All rights reserved. See the OKIDATA Business Partner Exchange (BPX) for any updates to this material. (<http://bpx.okidata.com>)

Adjustment Types and Functions

4.1.1 Printer Driver

This printer driver has the following functions:

- Drum counter reset
- Printer menu default
- Cleaning page generation

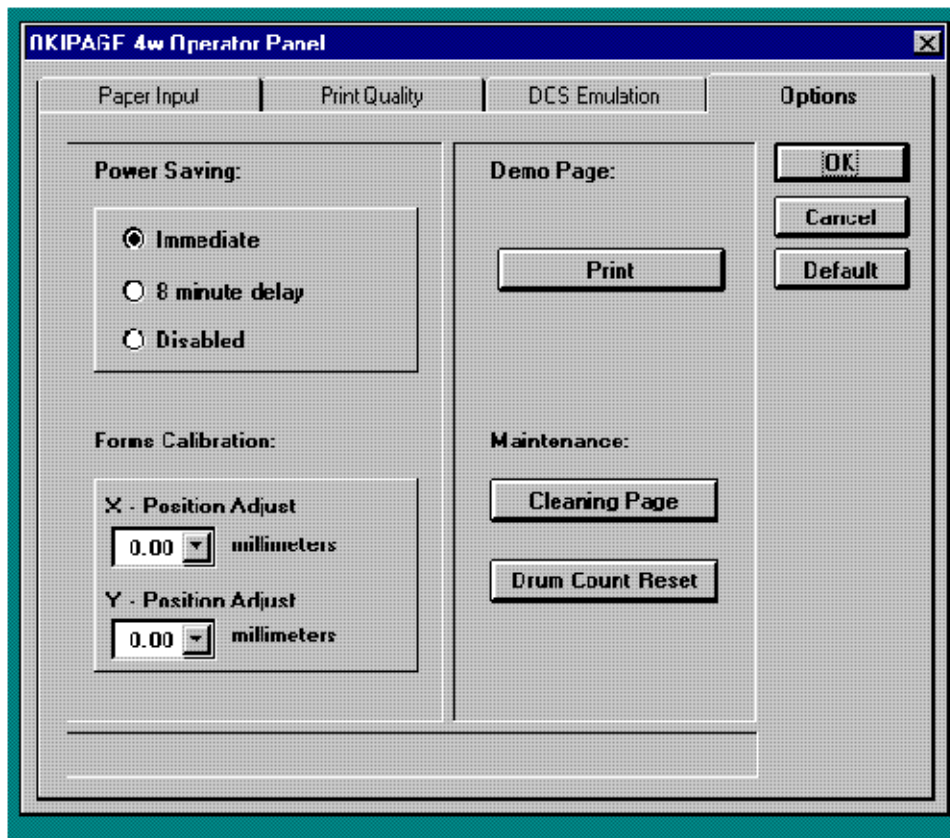

Figure 4-1

(1) Drum counter reset

This function resets the life of the drum counter when the image drum unit is replaced. Clicking the Drum Count Reset button resets the life.

(2) Printer menu default

This function returns the user-set menu contents to default settings. Clicking the Default button

automatically returns the user-set menu contents to default settings.

(3) Cleaning page

This function cleans the charge roller of the image drum unit; it is used when printing is unclear. For details on how to operate this function, refer to Soft Manual or Printer Information Guide.

4.1.2 Engine Maintenance Utility

See Appendix C.

Copyright 1997, Okidata, Division of OKI America, Inc. All rights reserved. See the OKIDATA Business Partner Exchange (BPX) for any updates to this material. (<http://bpx.okidata.com>)

Adjustment When Replacing a Part

The table below lists the parts that require adjustment when they are replaced.

Part to be Replaced	Adjustment
LED head	Set the LED head drive time. Set the LED head dot count.
Image drum unit	Reset the drum counter. (Refer to Soft Manual).
Main control board	Upload or download EEPROM data.

4.2.1 Setting LED Head Drive Time

Caution: When the luminous intensity of a new LED head is the same as that of the old LED head, do not set the LED head drive time.

Use LED Head Making No. in the engine menu tab of the maintenance driver to set the luminous intensity displayed on the LED head as the LED head drive time. (See Figure 4-2.)

- Luminous intensity of LED head

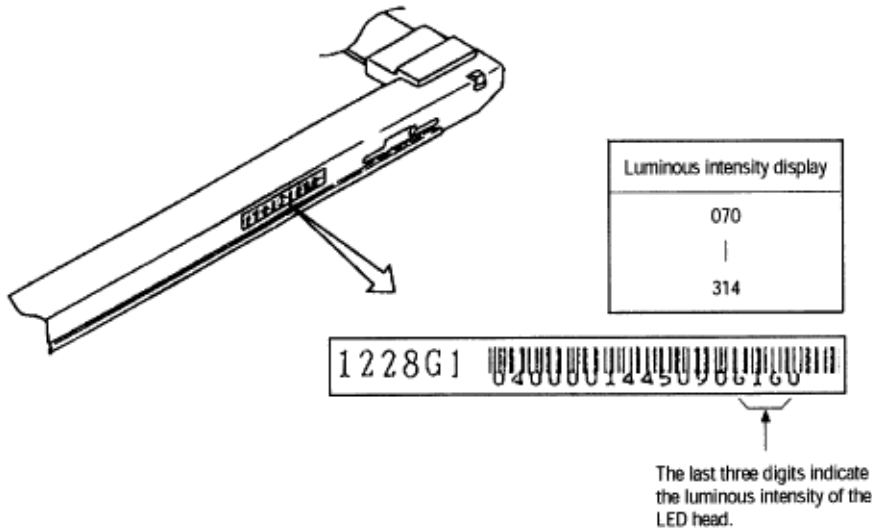

Figure 4-2

4.2.2 Setting the LED Head Dot Count

There are two possible LED head dot counts. Use the following label to identify these types. Use LED Head Width in the engine menu table to set the LED head dot count. (See Figure 4-2.)

- Identifying the types of LED head dot count

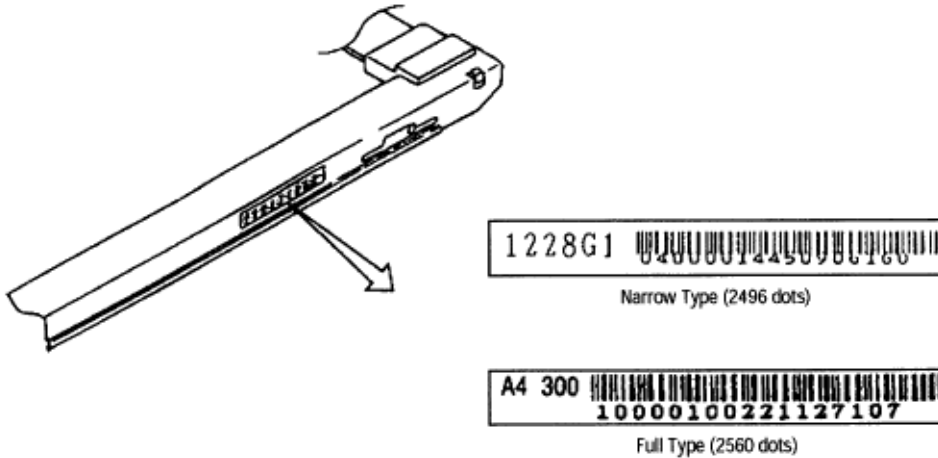

Figure 4-3

4.2.3 Uploading and Downloading EEPROM Data

When the main control board is replaced, data from the old EEPROM must be loaded into the EEPROM on the new board. Use EEPROM Operations in the option tab of the maintenance utility to download EEPROM data onto the new main control board. (See Figure 4-4.)

Download EEPROM data onto the new main control board in the following procedures:

- (1) Check that the printer and PC are connected by the parallel I/F, then run the maintenance utility.
- (2) Click the Option button in Main Menu Dialog.
- (3) Click the Upload button (Upload EEPROM Data) in EEPROM Operations. (EEPROM data read is completed.)
- (4) The read EEPROM data is displayed in Dialog of the maintenance driver.
- (5) Leave the display of the maintenance driver as is and replace the main control board.
- (6) Click the Download button (Download EEPROM Data) in EEPROM Operations. (EEPROM data write is completed.)

Depending on the level of a main control board failure (parallel I/O failure, etc.), however, EEPROM data may be unable to be uploaded.

In such a case, use the maintenance utility to perform the following adjustment after replacing the main control board:

- Setting the LED head drive time (See Section 4.2.1 above)
- Setting the LED head dot count (See Section 4.2.2 above)
- Setting specifications (ODA/OEL/INT-A/INT-L)

PERIODICAL MAINTENANCE

5.1 Periodical Replacement Parts

Table 5-1 lists the part and unit to be replaced periodically.

Table 5-1 Routine Replacement Parts

Part Name	Replacement Time	Parts to be Checked Simultaneously	Remarks
Toner cartridge	When "Toner Low" is displayed.	LED head	Consumables
Image Drum unit	When "Changed Drum" is displayed.		Consumables

Caution: Also reset the drum counter when replacing the EP unit.

Cleaning

Remove any toner or dirt and clean the circumference and inside of the printer with a disposable cloth.

Caution: Do not touch the image drum, LED lens array, or connector block of the LED head.

5.2.1 Cleaning the LED Lens Array

When a white band or a white stripe (void, light printing) occurs in the vertical direction of the print surface, clean the LED lens array or replace the toner cartridge.

Caution: Be sure to use an LED head cleaner to clean the LED lens array.

White band or stripe
(void, light printing)

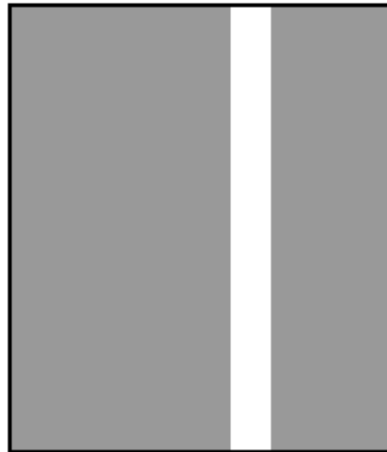

Figure 5-1

(1) Set the LED head cleaner in the LED lens array, as shown in the figure below, and slide the cleaner left and right several time to clean the head.

Caution: Do not press the LED head cleaner against the LED lens array.

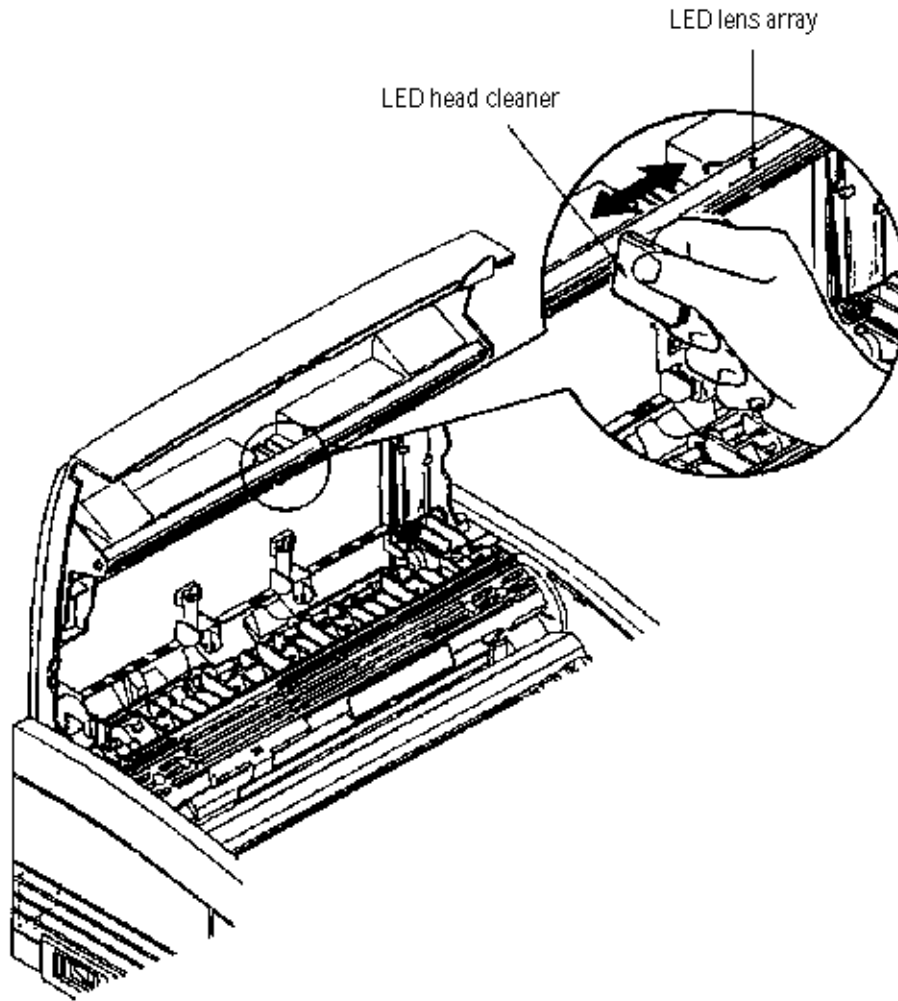

Figure 5-2

Copyright 1997, Okidata, Division of OKI America, Inc. All rights reserved. See the OKIDATA Business Partner Exchange (BPX) for any updates to this material. (<http://bpx.okidata.com>)

TROUBLESHOOTING PROCEDURES

6.1 Troubleshooting Tips

- (1) Check the basic check points in the Printer Information Guide or Soft Manual.
- (2) Gather as much detailed failure information as possible from the customer.
- (3) Check the printer under conditions close to that under which the failure occurred.

Copyright 1997, Okidata, Division of OKI America, Inc. All rights reserved. See the OKIDATA Business Partner Exchange (BPX) for any updates to this material. (<http://bpx.okidata.com>)



Service Guide OKIPAGE4w Chapter 6 Troubleshooting Procedures

Check Points Before Correcting Image Problems

- (1) Is the printer running in proper ambient conditions?
 - (2) Have consumables (toner and image drum) been replaced as needed?
 - (3) Is paper in good condition? Does it meet the specifications?
 - (4) Is the image drum seated properly?
-

Copyright 1997, Okidata, Division of OKI America, Inc. All rights reserved. See the OKIDATA Business Partner Exchange (BPX) for any updates to this material. (<http://bpx.okidata.com>)

Notes When Correcting Image Problems

- (1) Do not touch the surface of the image drum nor place foreign matter on it.
- (2) Do not expose the image drum to direct sunlight.
- (3) Do not touch the fuser, because it heats up during operation.
- (4) Do not expose the image drum to light for more than five minutes at room temperature.



Service Guide OKIPAGE4w

Chapter 6 Troubleshooting Procedures

Preparation Before Troubleshooting

(1) Message display

The failure status of the OKIPAGE 4w is displayed on the status monitor of the PC.

Take proper action according to the message displayed on the status monitor.

(2) LED display

The OKIPAGE 4w is equipped with only one LED. This LED indicates status as follows:

Printer Status	LED Indication
Ready	Lighting
Printing in progress	Blink (*1)
Recoverable alarm	Blink (*2)
Unrecoverable alarm	Blink (*3)

*1: The LED blinks at a cycle of 1 second (0.5s ON) from data reception to printing end.

*2: The LED blinks at a cycle of 0.24 second (0.12s ON).

*3: The LED blinks at a cycle of 0.24 second (0.12s ON).



Service Guide OKIPAGE4w Chapter 6 Troubleshooting Procedures

Troubleshooting

If a problem occurs in the OKIPAGE 4w, troubleshoot according to the following procedures:

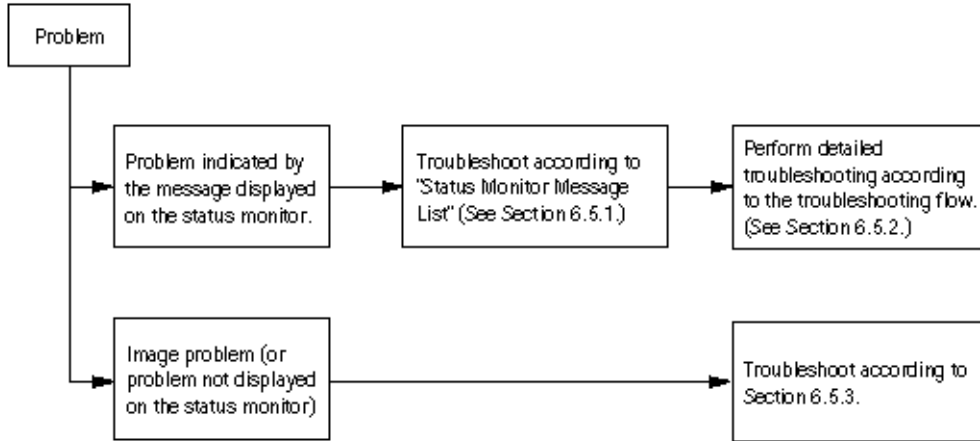



Service Guide OKIPAGE4w

Chapter 6 Troubleshooting Procedures

Status Monitor Message List

Table 6-1 lists the status messages and problems displayed on the status monitor.

Category	Status Message	Status Code	Explanation	Remedy
Normal status	Warming Up	18 00	Warming-up status.	Normal operation.
Normal status	Online (Ready)	00 10	Online (ready) status.	Normal operation.
Normal status	Power Save Mode	00 20	Power save status.	Normal operation.
Normal status	Toner Low	10 00	The toner amount of the toner cartridge is small.	Normal operation/replace the toner cartridge.
Normal status	Toner Sensor	10 01	The image drum is not installed or the toner sensor is faulty.	Install the image drum or replace the toner sensor.
Normal status	Change Drum	10 02	Image drum is nearing end of life.	Replace the image drum. Note: Be sure to reset the drum counter after replacing the image drum).
Normal status	Manual Paper In	12 20	The paper is in the manual feed mode.	Normal operation.
Normal status	Printing In Progress	14 20	Printing in progress.	Normal operation.
Normal status	Ejection in Progress	14 30	Ejection in progress.	Normal operation.
Normal status	Manual Request Executive Letter Legal 14 Legal 13 A6 A5 A4 B5 Monarch COM-10 DL C5 COM-9	16 01 16 02 16 03 16 04 16 18 16 19 16 1A 16 21 16 50 16 51 16 5A 16 5B 16 7F	Request the paper to be set in the manual feed mode. The paper sizes are as follows: Executive, Letter, Legal 14, Legal 13, A4, A5, A6, B5, Monarch, DL, C5, COM-10, COM-9.	Set the requested paper in the manual feed mode.

Paper size error	Paper Size Error	30 00	Paper of improper size was fed. 2.52" (64 mm) L 15.77" (400.56 mm)	Check the paper. Also check whether more than one sheet of paper were fed simultaneously. To clear the error display, open the cover, then close it.
Paper jam	Paper Input Jam	31 00	A paper jam occurred when sheets of paper were being supplied.	Check the paper. To release the error display, open the cover, then close it.
Paper jam	Paper Feed Jam	32 00	A paper jam occurred during paper feeding.	Open the cover, then remove the jammed paper. To clear the error display, close the cover.
Paper Jam	Paper Exit Jam	33 00	A Paper jam occurred during paper ejection.	Open the cover, then remove the jammed paper. To clear the error display, close the cover.
Cover Open	Cover Open	4F 00	The upper cover is open.	To clear the error display, close the cover. If this error occurs frequently, replaced the power supply board.
Buffer overflow	Page Buffer Overflow	40 01	The page buffer overflowed because there are a large number of print data.	To release the error display, press the reset button on the status monitor of the printer driver. Install option RAM or reduce the number of print data.
Buffer overflow	Print Over Run	40 10	A print overrun occurred because print data is complicated.	To clear the error display, press the reset button on the status monitor of the printer driver. Simplify the print data format.
Device configuration error	Program ROM Check Error	60 10	An error occurred during program ROM check.	Replace program ROM or the main control board. (When replacing the main control board, also adjust EEPROM data).

Device configuration error	Resident RAM Check Error	60 30	An error occurred during resident RAM check.	Replace the main control board. (When replacing the main control board, also adjust EEPROM data).
Device configuration error	EEPROM Check Error	60 40	An error occurred during EEPROM check.	Replace the main control board. (When replacing the main control board, also adjust EEPROM data).
Device configuration error	Option RAM Check Error	60 60	An error occurred during option RAM check.	Check the connection of the Option RAM PC board. If the option RAM PC board is faulty, replace it.
Device configuration error	Fuser Error	60 80	A heater timeout error occurred.	<u>See Fuser Assy Error</u> 
Device configuration error	Thermistor Error	60 90	A thermistor error occurred.	Replace the heat Assy.
Device configuration error	Thermistor Open Check Error	60 91	The thermistor is open.	Replace the heat Assy.
Device configuration error	Thermistor Short Check Error	60 92	A thermistor short occurred.	Replace the heat Assy.
Device configuration error	Watch Dog Timeout Error	60 00	A watchdog timeout occurred.	To clear the error display, turn on the power supply again. Replace the main control board.



Service Guide OKIPAGE4w

Chapter 6 Troubleshooting Procedures

Status Message Troubleshooting

Some failures cannot be corrected according to the status message trouble list. Troubleshoot these failures according to the following troubleshooting flowcharts:

No.	Item	Flowchart No.
1.	The OKIPAGE 4w malfunctions after the power supply has been turned on.	1
2.	Jam error <ul style="list-style-type: none"> — Paper input jam — Paper feed jam — Paper exit jam 	2-1 2-2 2-3
3.	Paper size error	3
4.	Fusing error	4

Caution: When replacing the main control board troubleshooted according to the troubleshooting flowcharts, also adjust EEPROM data.

Copyright 1997, Okidata, Division of OKI America, Inc. All rights reserved. See the OKIDATA Business Partner Exchange (BPX) for any updates to this material. (<http://bpx.okidata.com>)

The OKIPAGE 4w malfunctions after the power supply has been turned on.

1 The OKIPAGE 4w malfunctions after the power supply has been turned on.

- Turn the power supply off, then on again.

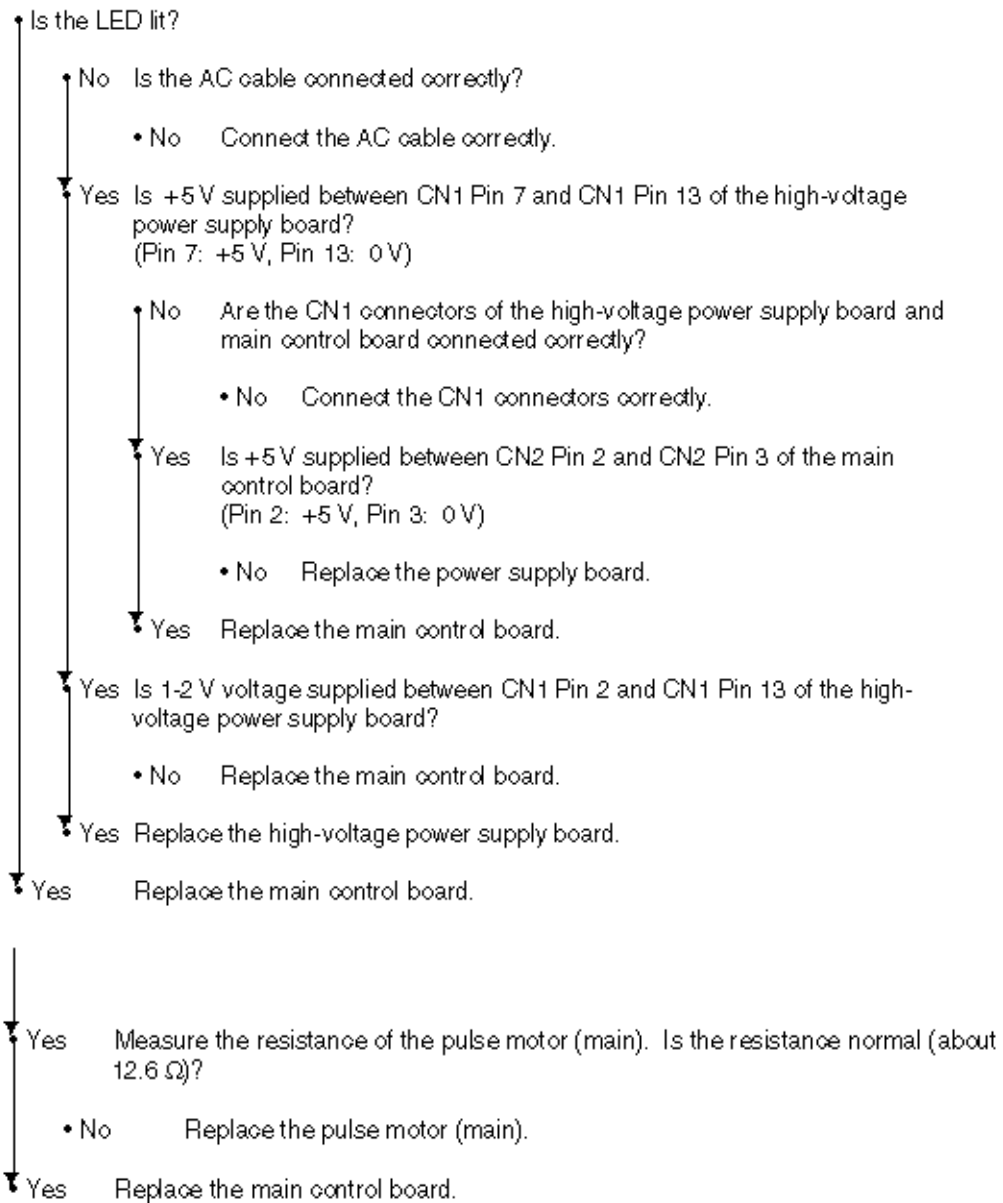

Exchange (BPX) for any updates to this material. (<http://bpx.okidata.com>)

[JAM error]

Paper input jam

2 - 1 Paper input jam

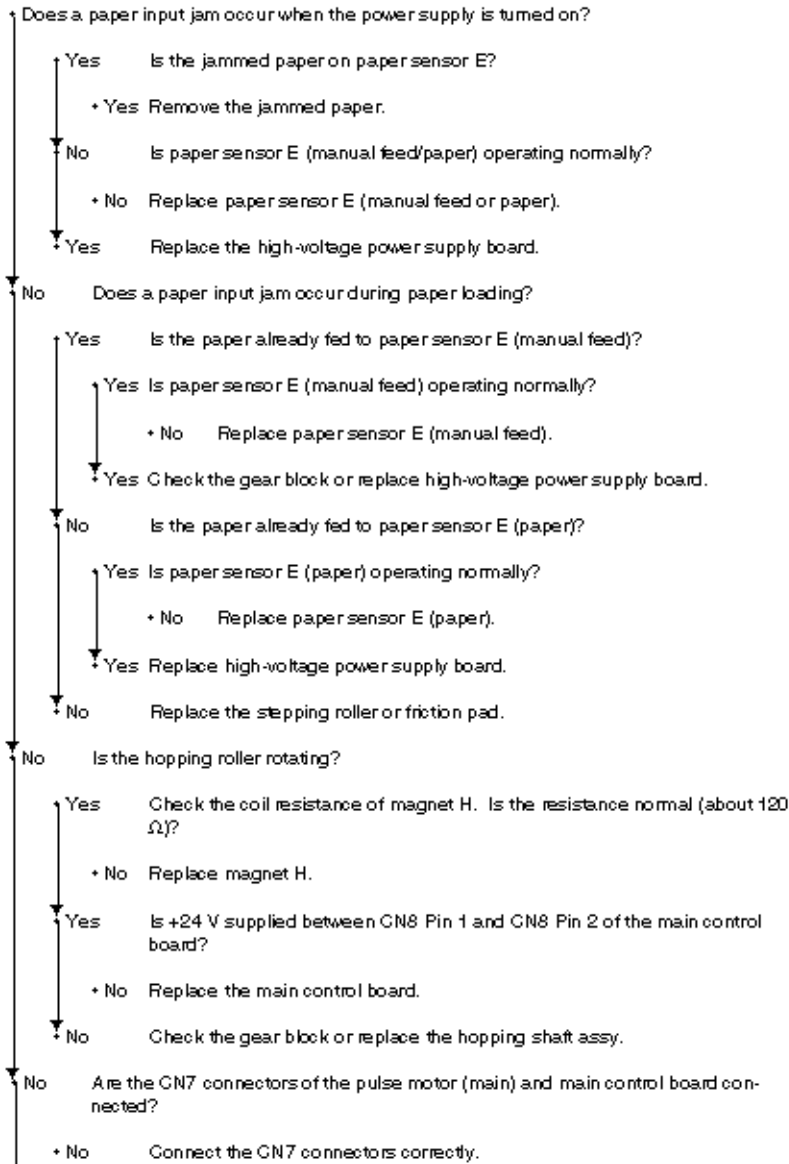

[JAM error]

Paper feed jam

2-2 Paper feed jam

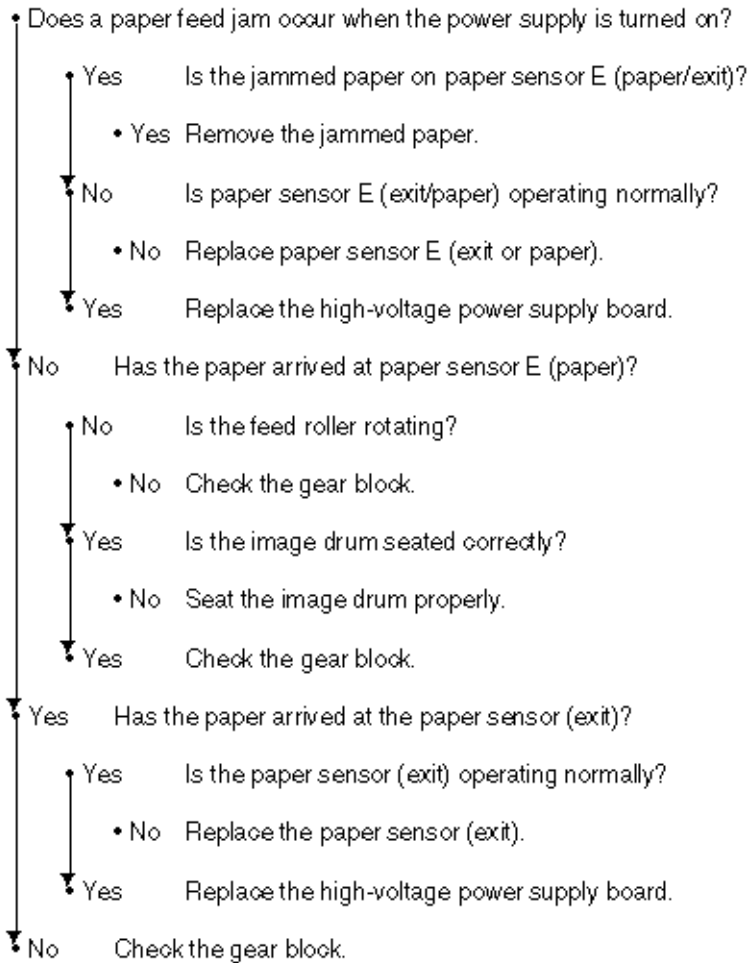

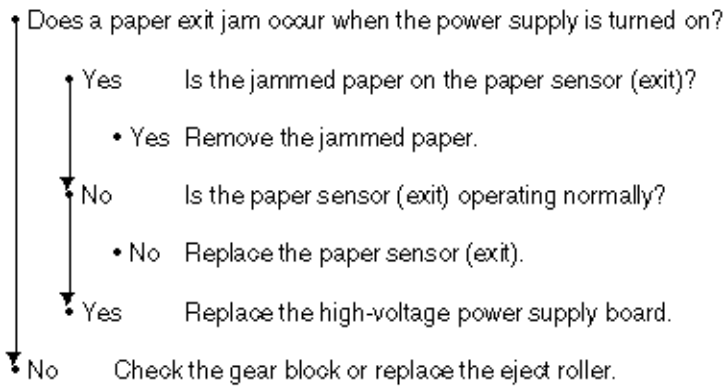
Paper exit jam**2-3 Paper exit jam**

Paper size error

3 Paper size error

- Is the paper of the specified size being used?
 - No Use paper of the specified size.
- Yes Is paper sensor E (paper) operating normally?
 - No Replace paper sensor E (paper) or clean the inlet sensor on the high-voltage power supply board.
- Yes Is the paper sensor (exit) operating normally?
 - No Replace the paper sensor (exit) or clean the outlet sensor on the high-voltage power supply board.
- Yes Replace the high-voltage power supply board.

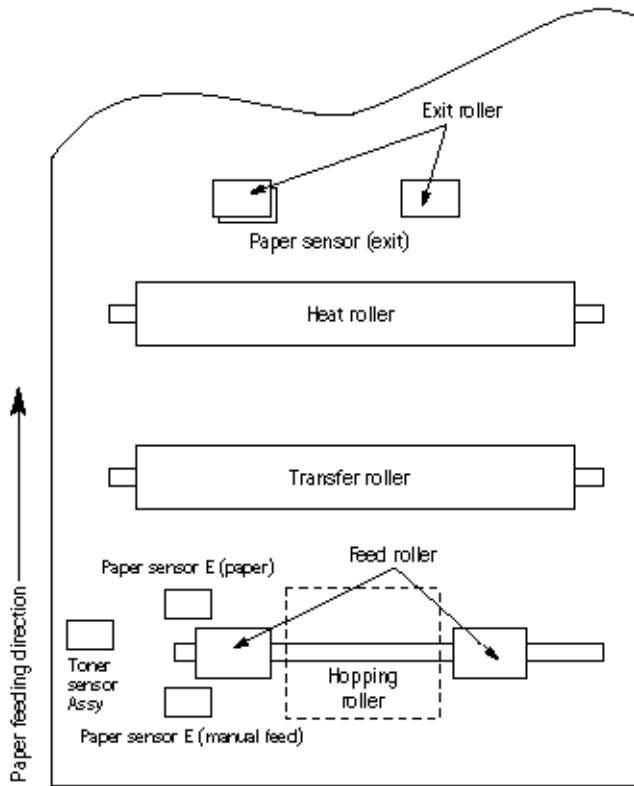

Copyright 1997, Okidata, Division of OKI America, Inc. All rights reserved. See the OKIDATA Business Partner Exchange (BPX) for any updates to this material. (<http://bpx.okidata.com>)

Fuser assy error**4** Fuser assy error

- Turn the power supply off, then on again.

• Does the Halogen lamp of the heat assy go on?

• No Is the Halogen lamp or thermostat disconnected?

- Yes Replace the fuser assy.

• No Replace the power supply unit.

• Yes Are the CN2 connectors of the power supply unit and main control board connected correctly?

- No Connect the CN2 connectors properly.

• Yes Replace the main control board.

Image Troubleshooting

This section explains how to troubleshoot when an image problem occurs.

Figure 6-3 gives examples of image problems.

Symptom	Flowchart No.
An image is light or blurred entirely. (Figure 6-3, (A))	1
Dark background density. (Figure 6-3, (B))	2
Blank paper. (Figure 6-3, (C))	3
Vertical block band/black stripe (Figure 6-3, (D))	4
Cyclical defect (Figure 6-3, (E))	5
Print void	6
Poor fusing (An image is blurred or peeled off when it is touched.)	7
Vertical white band/white stripe (Figure 6-3, (F))	8



(A) Light or blurred images entirely



(B) Dark background density



(C) Blank paper

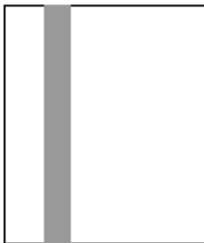

(D) Black vertical stripes

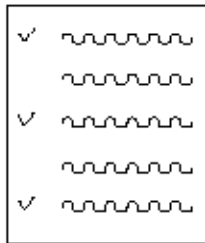

(E) Cyclical defect



(F) White vertical belts or streaks

Figure 6-3 Image Problems

Copyright 1997, Okidata, Division of OKI America, Inc. All rights reserved. See the OKIDATA Business Partner Exchange (BPX) for any updates to this material. (<http://bpx.okidata.com>)

An image is light or blurred entirely.

1 An image is light or blurred entirely.

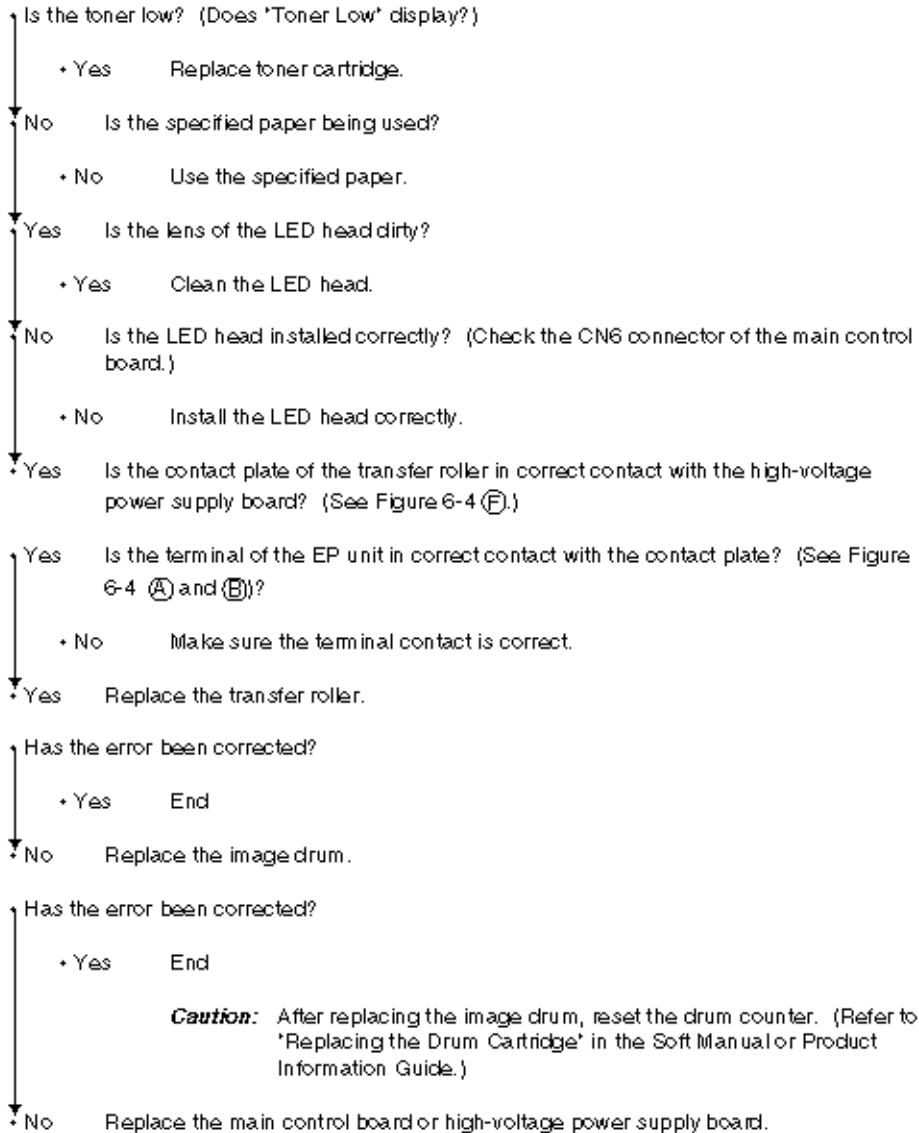

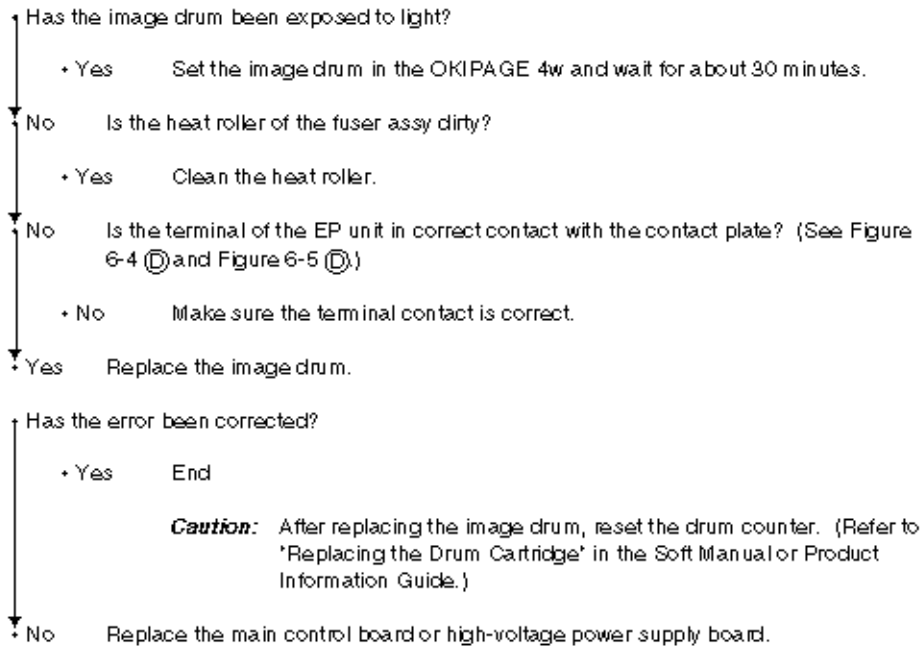
Dark background density**2** Dark background density

Paper is blank.

3 Paper is blank

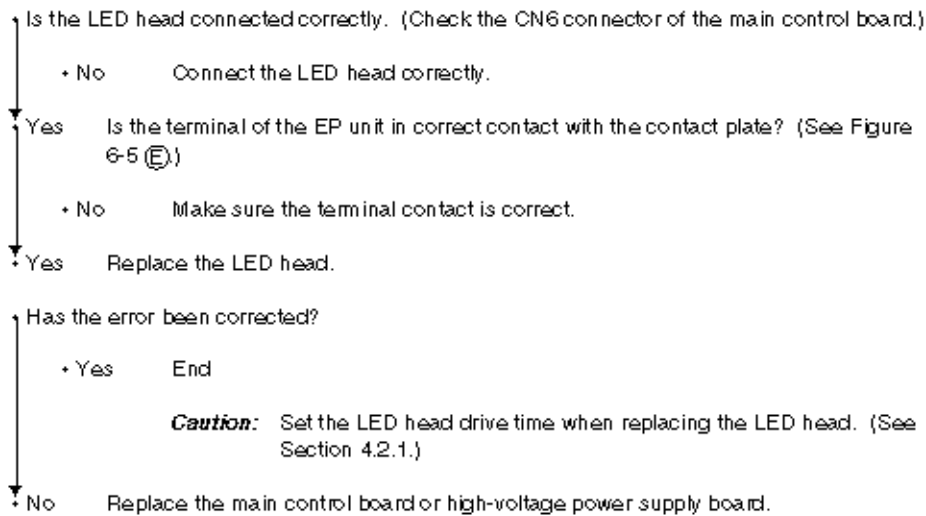



Service Guide OKIPAGE4w

Chapter 6 Troubleshooting Procedures

Vertical black band/stripe

4 Vertical black band/stripe

- Replace the image drum.

Has the error been corrected?

- Yes End

Caution: After replacing the image drum, reset the drum counter. (Refer to 'Replacing the Drum Cartridge' in the Soft Manual or Product Information Guide.)

- No Replace the LED head.

Has the error been corrected?

- Yes End

Caution: Set the LED head drive time when replacing the LED head. (See Section 4.2.1.)

- No Replace the main control board or high-voltage power supply board.

	Cycle	Remedy
Image Drum	1.98" (50.3 mm)	Clean or replace the EP unit.
Developing roller	1.44" (36.6 mm)	Replace the image drum.
Toner supply roller	2.63" (66.8 mm)	Replace the image drum.
Charge roller	0.81" (20.6 mm)	Replace the image drum.
Cleaning roller	0.81" (20.6 mm)	Replace the image drum.
Transfer roller	1.71" (43.4 mm)	Replace the image drum.
Heat roller	2.46" (62.5 mm)	Replace the heat roller.
Pressure roller B	1.98" (50.3 mm)	Replace pressure roller B.



Service Guide OKIPAGE4w Chapter 6 Troubleshooting Procedures

Cyclic defect

Caution: After replacing the image drum , reset the drum counter. (Refer to "Replacing the Drum Cartridge" in Soft Manual or Product Information Guide.)

Copyright 1997, Okidata, Division of OKI America, Inc. All rights reserved. See the OKIDATA Business Partner Exchange (BPX) for any updates to this material. (<http://bpx.okidata.com>)

Print voids.

6 Print voids.

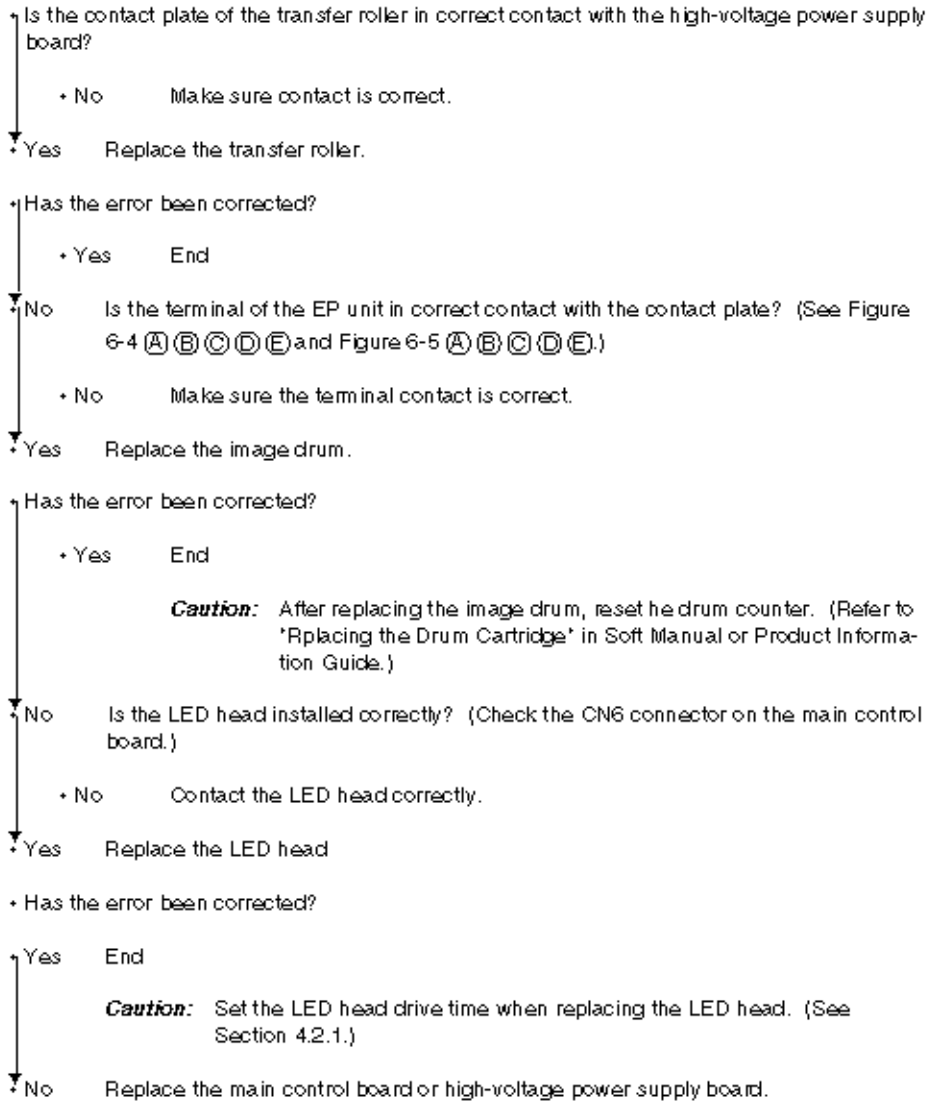

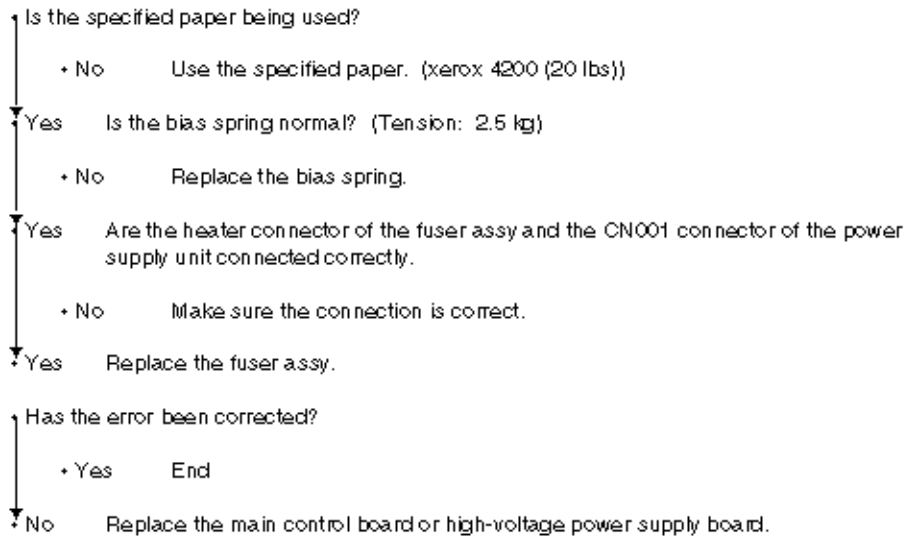
Poor fusing**7** Poor fusing

Vertical white band/stripe

8 Vertical white band/stripe

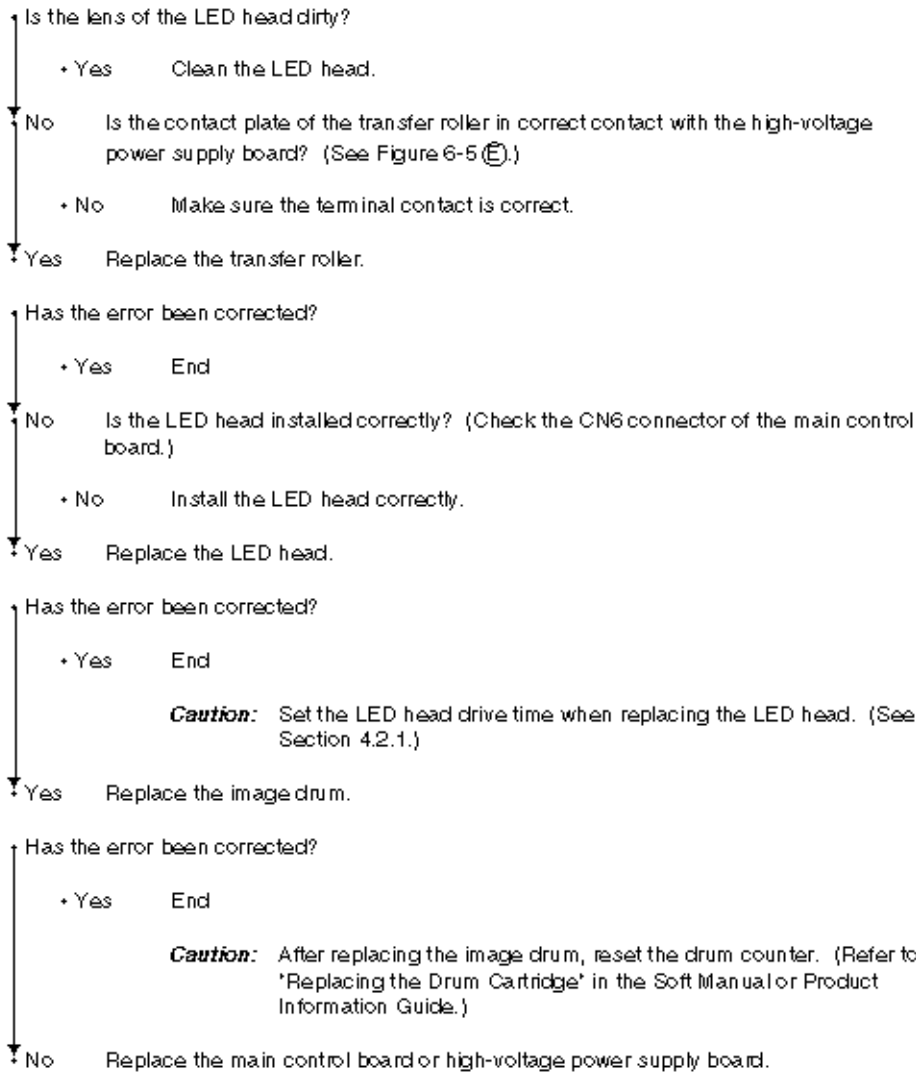

Figure 6-4**Contents**

- A : Toner Supply Roller
- B : Developing Roller
- C : Charge Roller
- D : Cleaning Roller
- E : Transfer Roller
- F : Heat Roller

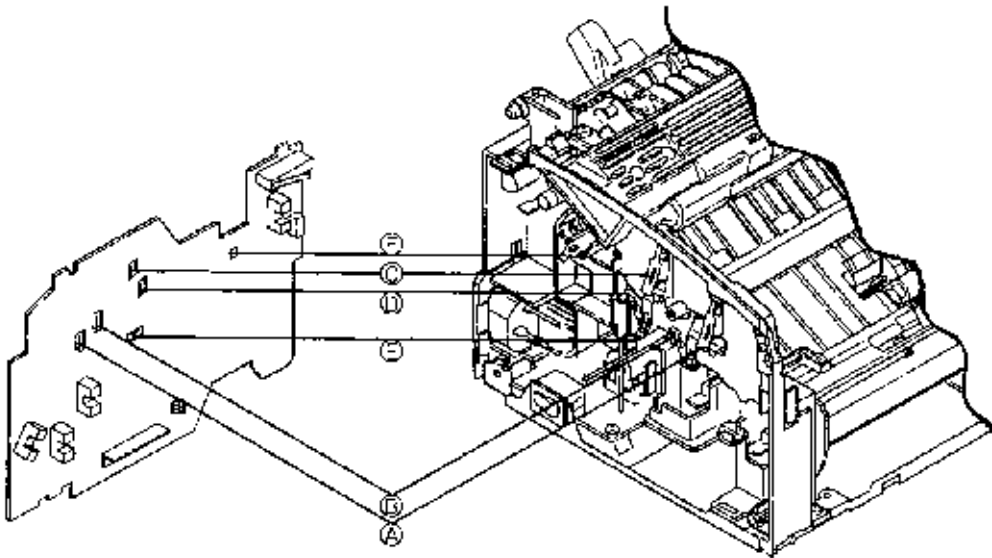

Figure 6-5**Contents**

A : Toner Supply Roller

B : Developing Roller

C : Charge Roller

D: Cleaning Roller

E : Ground (Drum)

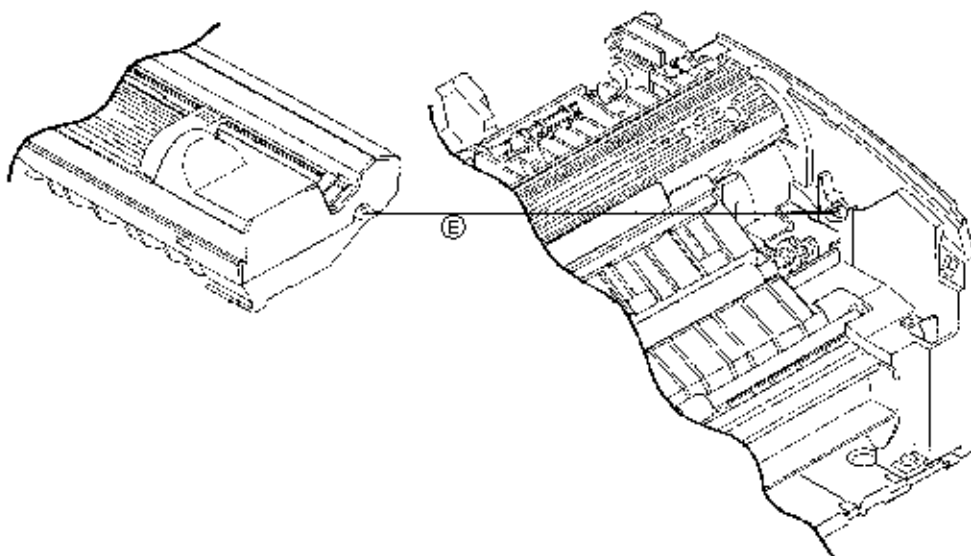
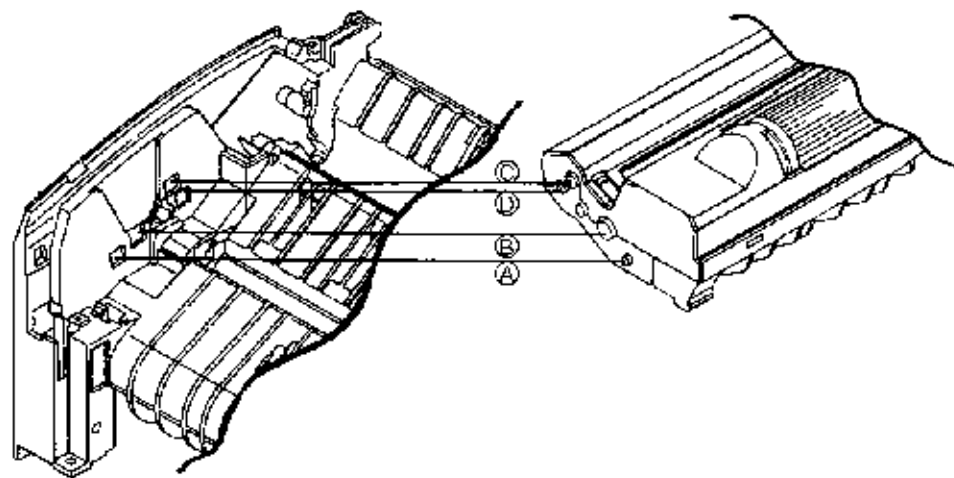

Copyright 1997, Okidata, Division of OKI America, Inc. All rights reserved. See the OKIDATA Business Partner Exchange (BPX) for any updates to this material. (<http://bpx.okidata.com>)



Service Guide OKIPAGE4w

Chapter 7 Wiring Diagram

WIRING DIAGRAM

7.1 Interconnect Signal Diagram

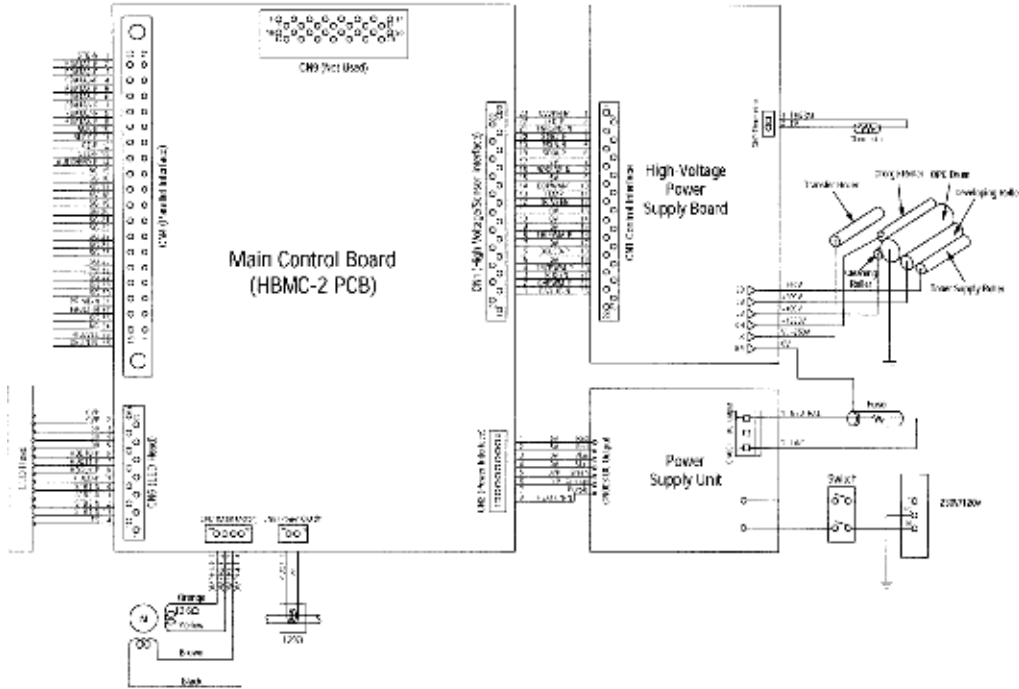

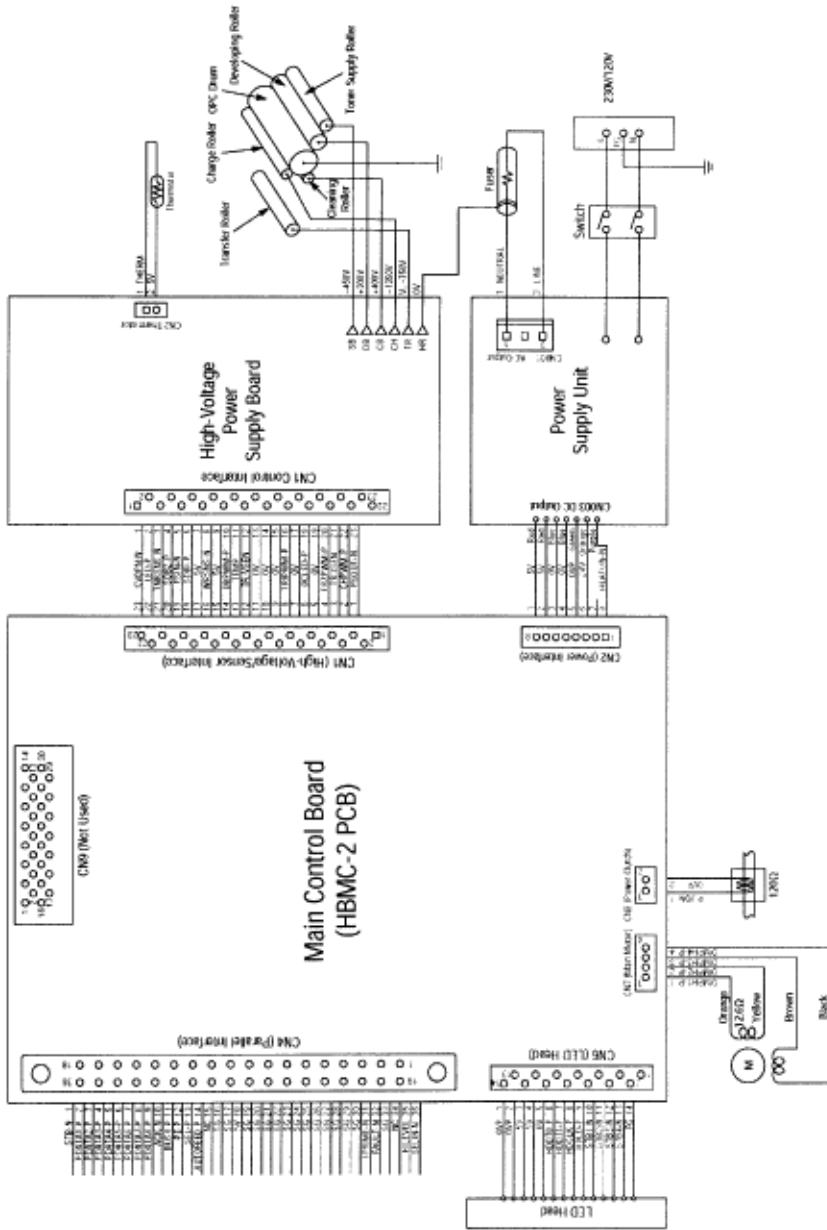

Copyright 1997, Okidata, Division of OKI America, Inc. All rights reserved. See the OKIDATA Business Partner Exchange (BPX) for any updates to this material. (<http://bpx.okidata.com>)

PCB Layout

(1) Main Control Board (HBMC-2 PCB)

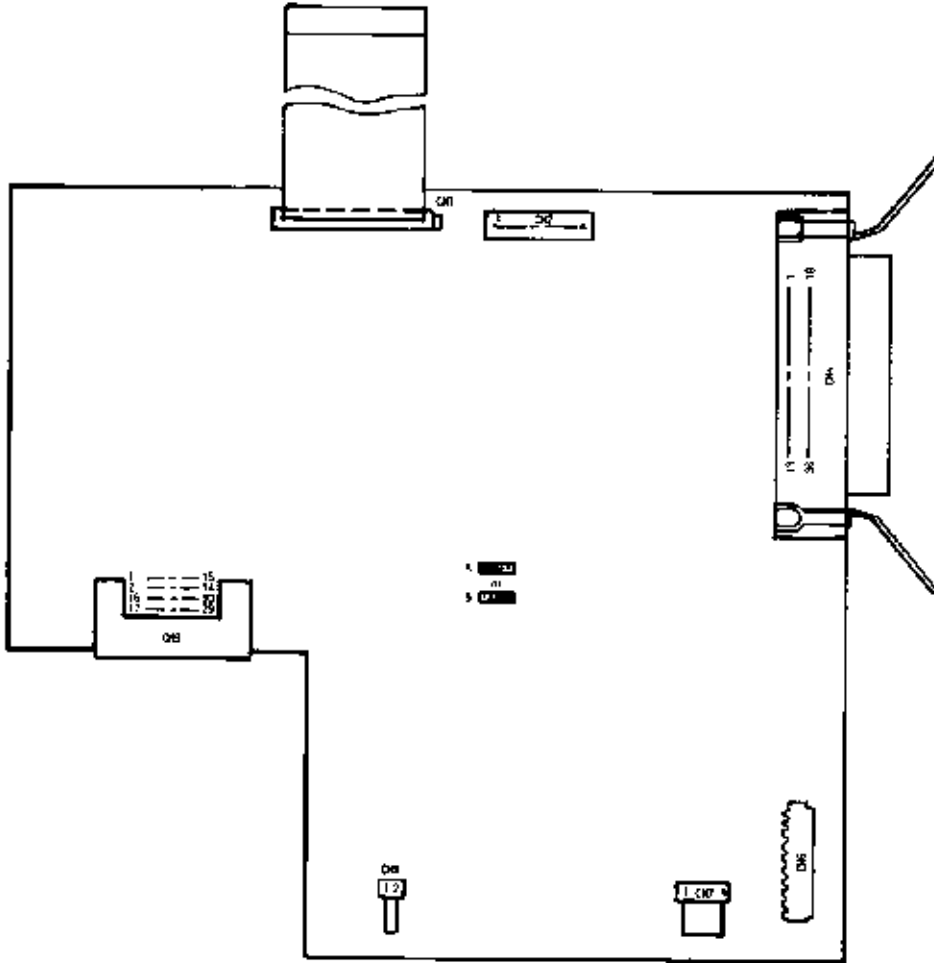

Short Plug	Plug Setting	Content
SP1	A	External EPROM is valid.
SP1	B	Mask ROM in the CPU is valid.

(2) High-Voltage Power Supply Board

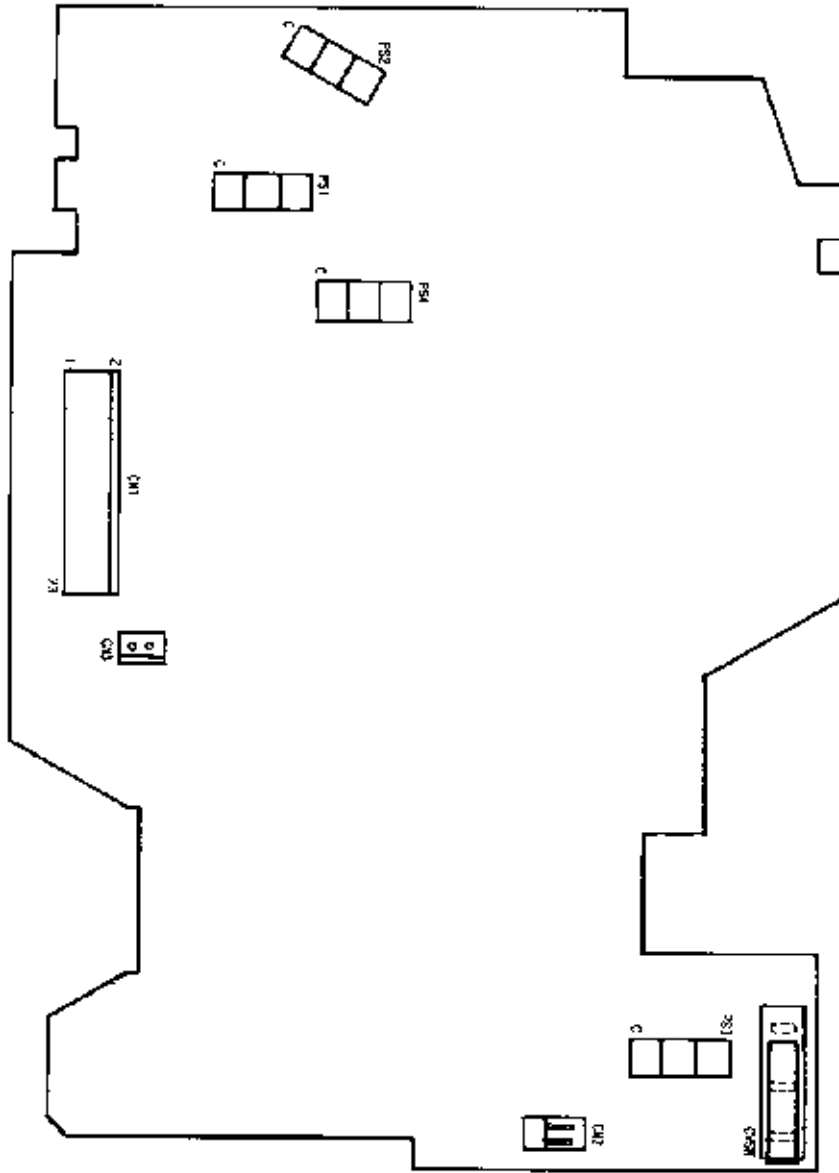

Copyright 1997, Okidata, Division of OKI America, Inc. All rights reserved. See the OKIDATA Business Partner Exchange (BPX) for any updates to this material. (<http://bpx.okidata.com>)

Cover Assy Upper

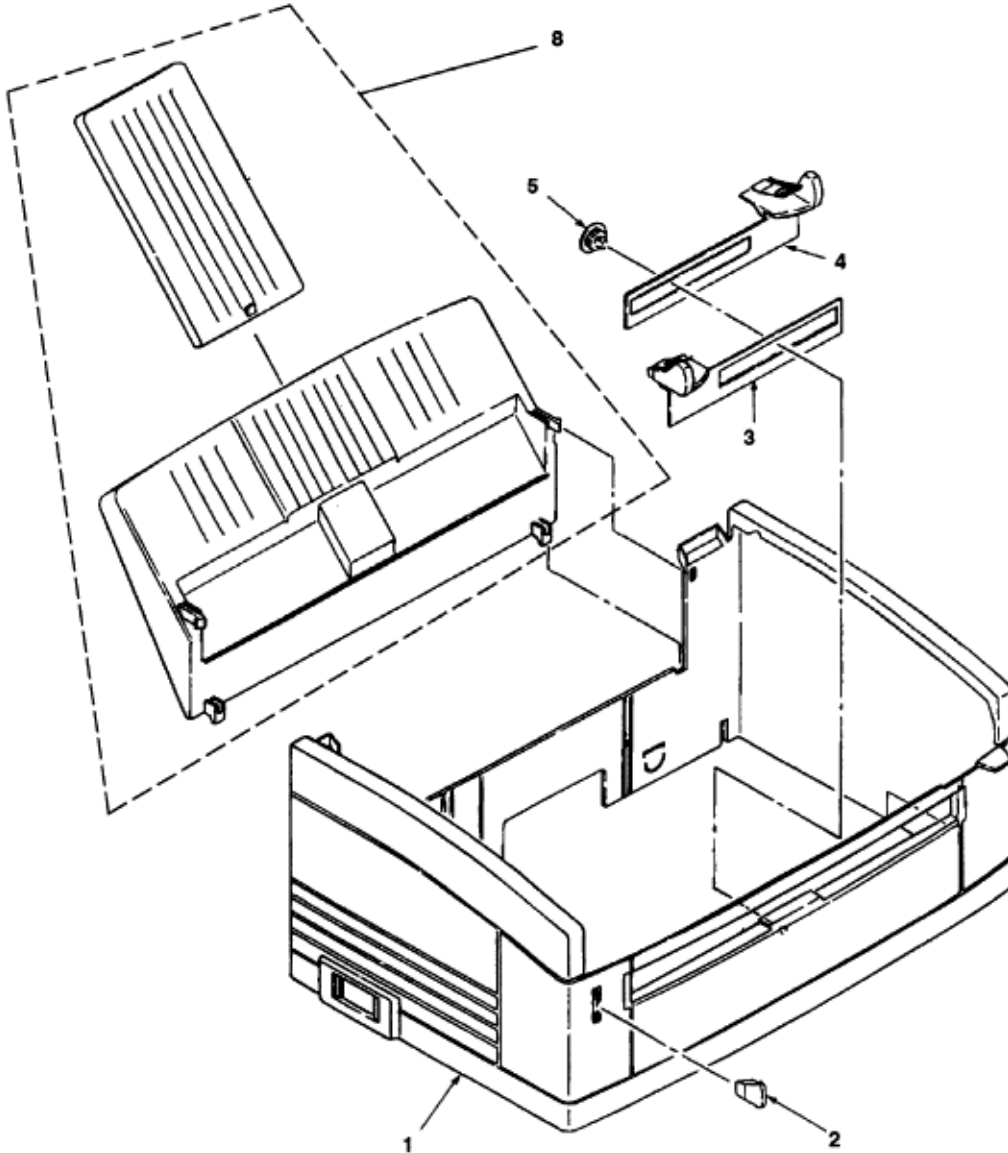

Figure 8-1 Cover Assy Upper

Table 8-1 Cover Assy Upper

No.	Part Name	Part No.	Q'ty	Remarks
1	Upper Cover	1PP4128-1251P1	1	53076201
2	Lamp	3PP4128-1255P1	1	56108401
3	Guide Slide (L)	2PP4128-1256P1	1	51021001
4	Guide Slide (R)	2PP4128-1257P1	1	51021101
5	Spur Gear (A)	4PP4128-1260P1	1	51237301
6	_____	_____	_____	_____
7	_____	_____	_____	_____
8	Paper Support Assembly	2PA4128-1272G1	1	51023001

Copyright 1997, Okidata, Division of OKI America, Inc. All rights reserved. See the OKIDATA Business Partner Exchange (BPX) for any updates to this material. (<http://bpx.okidata.com>)

Base Frame Unit

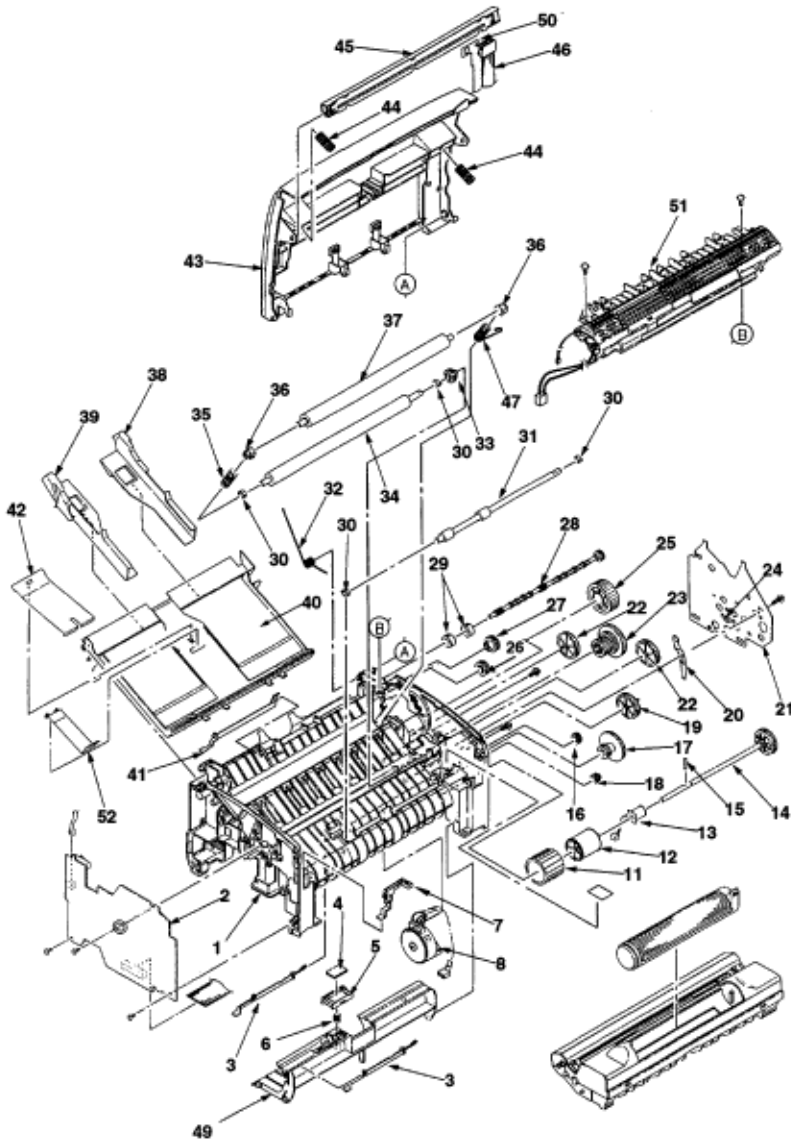

Figure 8-2 Base Frame Unit

Table 8-2 Base Frame Unit

No.	Part Name	Part No.	Q'ty	Remarks
1	Base Frame Assy	2PA4083-1132G1	1	50221701
2	High-Voltage Power Supply Board	4YA4130-1004G1	1	55080401
3	Paper Sensor E	3PP4083-1191P1	2	50410601
4	Friction Pad	4PB4083-1245P1	1	51711701
5	Separator Guide	3PP4083-1244P1	1	51021701
6	Compression Spring S	4PP4083-1246P1	1	50931001
7	Toner Sensor Assy	3PA4083-1193G1	1	50410801
8	Pulse Motor (Main)	4PB4083-1172P1	1	56513501
9	_____	_____	_____	_____
10	_____	_____	_____	_____
11	Hopping Roller	4PB4083-1129P1	1	53348201
12	Roller Holder (Hopping Roller)	3PP4083-1128P1	1	50708801
13	Magnet H (Hopping Shaft)	3PB4083-1127P1	1	50809001
14	Hopping Shaft Assy	3PA4083-1133G1	1	51113901
15	Knock Pin	NK2-10-SUS	1	50607701
16	Idle Gear R	4PP4083-1143P1	1	51237501
17	Idle Gear 2R	3PP4083-1184P1	1	51238001
18	Gear R	3PP4083-1142P1	1	51237401
19	Idle Gear M	3PP4083-1181P1	1	51237701
20	Earth Plate A	3PP4083-1189P1	1	51021501
21	Side Plate M	3PP4083-1188P1	1	51021401
22	Idle Gear P	3PP4083-1182P1	2	51237801
23	Idle Gear 3R	3PP4083-1183P1	1	51237901
24	Tension Plate	4PP4083-1165P1	1	51022601
25	Idle Gear Heat	3PP4083-1185P1	1	51238101
26	Idle Gear E (A)	4PP4083-1186P1	1	51238201
27	Idle Gear E (B)	3PP4083-1187P1	1	51238301
28	Shaft, Eject Roller	40074601	1	40074601
29	Eject Roller	4PB4083-1171P1	2	53348601
30	Resistration Bearing	3PP4083-1141P1	4	51609101
31	Resistration Roller	3PB4083-1140P1	1	53348301
32	Torsion Spring	4PP4083-1252P1	1	50930801
33	Gear T (transfer)	3PP4083-1151P1	1	51237601
34	Transfer Roller	3YB4083-1150P1	1	53348401

No.	Part Name	Part No.	Q'ty	Remarks
35	Bias Spring (L) (Back Up Roller)	4PP4083-1136P1	1	50931701
36	Bearing BU (Back Up Roller)	3PP4083-1161P1	2	51609201
37	Pressure Roller B (Back Up Roller)	3PB4083-1160P2	1	53348502
38	Paper Guide (R)	3PP4083-1233P1	1	51021901
39	Paper Guide (L)	3PP4083-1232P1	1	51021801
40	Paper Holder	1PP4083-1231P1	1	50708901
41	Paper Sensor Exit	3PP4083-1192P1	1	50410701
42	Hopper Spring	4PP4083-1247P1	1	50931101
43	Top Cover Assy (ODA)	2PA4128-1271G1	1	53076301
	Top Cover Assy (OEL/OKI-INT)	2PA4128-1271G2	1	_____
44	Head Spring	4PP4083-6168P1	2	50928701
45	LED Head	4YA4116-1228G1	1	56112101
46	Flat Cable Assy (LED Head)	4YX4083-1134G1	1	56633401
47	Bias Spring (R) (Back Up Roller)	4PP4083-1137P1	1	50930901
48	_____	_____	—	_____
49	Sheet Guide	1PP4083-1241P1	1	51021601
50	Film FG	40011401	1	40011401
51	Fuser Assy, 120V	1YX4083-1200G1	1	56802601
	Fuser Assy, 230V	1YX4083-1200G2	1	_____
52	Stopper Spring	40034001	1	40034001

Copyright 1997, Okidata, Division of OKI America, Inc. All rights reserved. See the OKIDATA Business Partner Exchange (BPX) for any updates to this material. (<http://bpx.okidata.com>)

Base Plate Unit

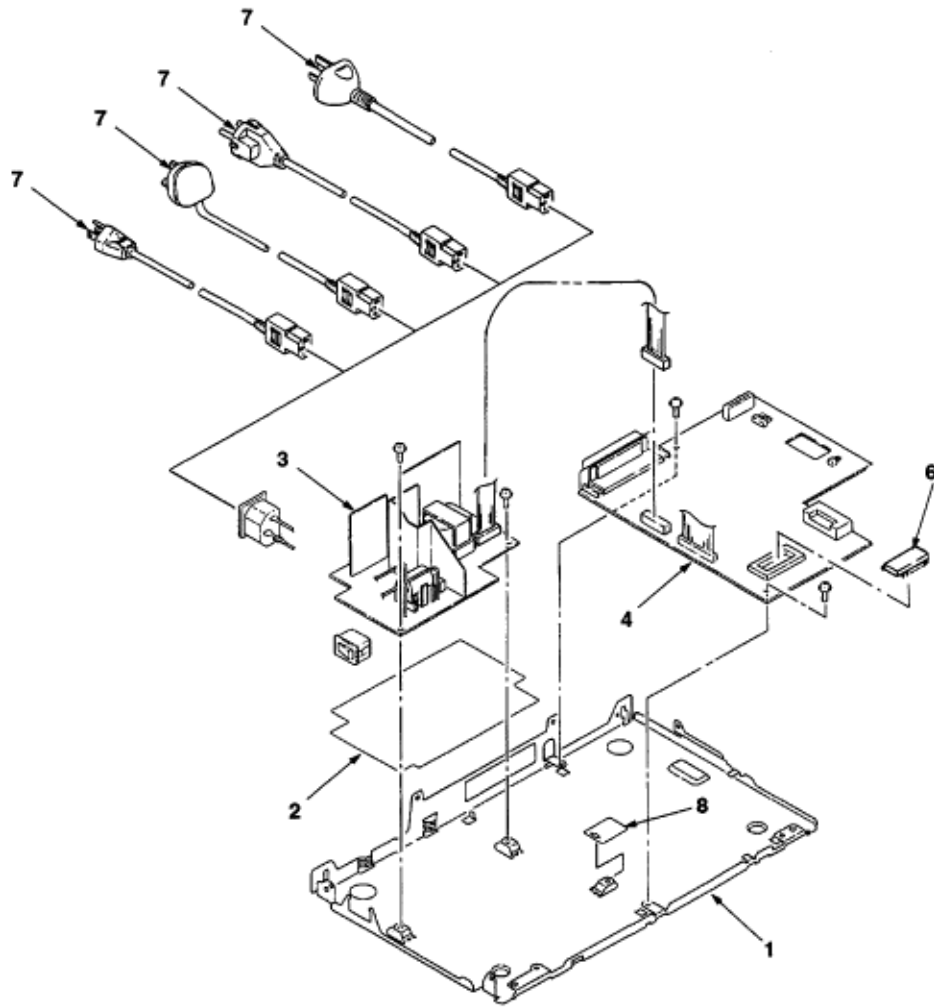

Table 8 Base Plate Unit

No.	Part Name	Part No.	Q'ty	Remarks
1	Base Plate Assy	3PA4083-1135G1	1	51020901
2	Insulation Sheet	3PB4083-1251P1	1	51711601
3	Power Supply Unit, 120V	4YB4049-1853P1	1	56415101
	Power Supply Unit, 230V	4YB4049-1854P1	1	—————
4	Main Control Board (HBMC-2 PCB), Without ROM	4YA4121-2516G2	1	55080502
6	Program ROM	4YR4077-1670G1	1	EP ROM
7	AC Cord, USA	3YS4011-1315P1	1	56609701
	AC Cord	3YS4011-1266P1	1	Continental
	AC Cord	3YS4011-1270P1	1	U.K.
	AC Cord	3YS4011-1329P2	1	Australia
8	Insulation Sheet B	40043001	1	40043001

Copyright 1997, Okidata, Division of OKI America, Inc. All rights reserved. See the OKIDATA Business Partner Exchange (BPX) for any updates to this material. (<http://bpx.okidata.com>)



Service Guide OKIPAGE4w

Chapter A Local Printing

LOCAL PRINTING

(1) The following operation enables the OKIPAGE 4w to print data by itself.

Operation

With the cover open, turn on the AC switch and then close the cover. The following patterns prints.

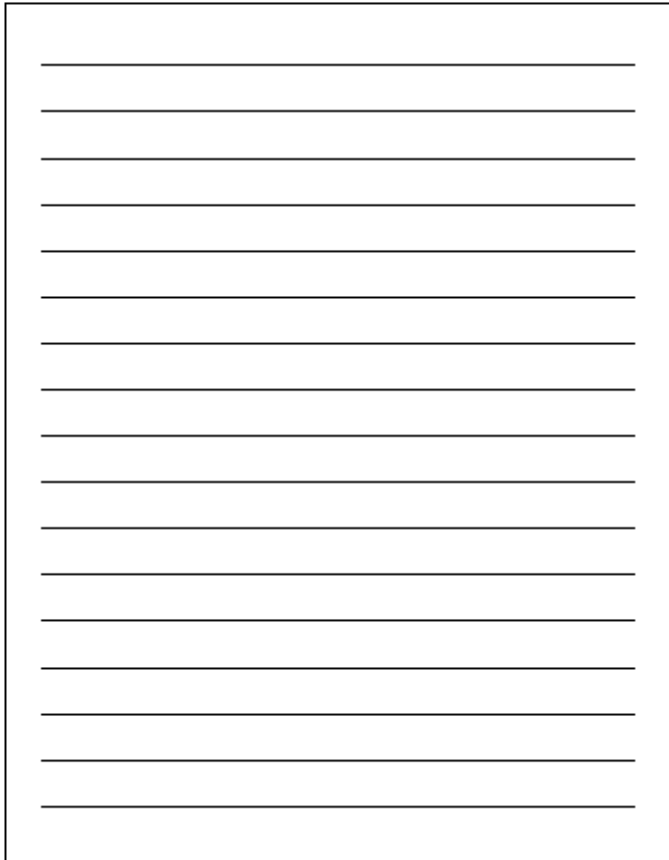

PARALLEL INTERFACE

(1) Connector

- Printer side : 36-pin receptacle Type: 57RE-40360-730B-D29A (Daiichi Denshi) or equivalent
- Cable side : 36-pin plug Type: 57-30360 (Daiichi Denshi) or equivalent

Copyright 1997, Okidata, Division of OKI America, Inc. All rights reserved. See the OKIDATA Business Partner Exchange (BPX) for any updates to this material. (<http://bpx.okidata.com>)



Service Guide OKIPAGE4w Chapter B Parallel Interface

(2) Cable

- Cable length : 6 feet (1.8 m) max. (A Shielded cable composed of twisted pair wires is recommended for noise prevention.)

Copyright 1997, Okidata, Division of OKI America, Inc. All rights reserved. See the OKIDATA Business Partner Exchange (BPX) for any updates to this material. (<http://bpx.okidata.com>)

(3) Parallel I/F signals

Pin No.	Signal Name	Direction	Function (Compatible Mode)
1	DATA STROBE	→ PR	Parallel data sampling strobe
2	DATA BIT - 1		
3	DATA BIT - 2		
4	DATA BIT - 3		
5	DATA BIT - 4	↔ PR	Printer parallel input/output data
6	DATA BIT - 5		
7	DATA BIT - 6		
8	DATA BIT - 7		
9	DATA BIT - 8		
10	ACKNOWLEDGE	← PR	Completion of input data reception
11	BUSY	← PR	The OKIPAGE 4w is not ready to receive data.
12	PAPER END	← PR	Paper end detection
13	SELECT	← PR	Select state (Online)
14	AUTOFD	→ PR	Carriage return control
15	-		Not used
16	0V		Grounding for signals
17	CHASSIS GROUND		Frame ground
18	+5V	← PR	50 mA max.
19			
20	0V		Grounding for signals
21			
22			
23			
24			
25			
26			
27			
28			
29			
30			
31	INPUT PRIME	→ PR	Initialization signal
32	FAULT	← PR	Paper end or alarm
33	0V		Grounding for signals
34	-		Not used
35	-		High level (3.3 kΩ)
36	SELIN	→ PR	Data input enable or disable

• Connector pin arrangement

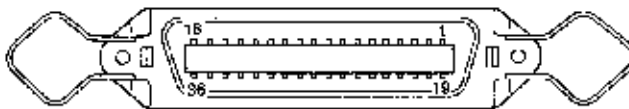

Copyright 1997, Okidata, Division of OKI America, Inc. All rights reserved. See the OKIDATA Business Partner Exchange (BPX) for any updates to this material. (<http://bpx.okidata.com>)



Service Guide OKIPAGE4w

Chapter B Parallel Interface

(4) Signal level

- LOW : 0 V to +0.8 V

- HIGH : +2.4 V to 5.0 V

Copyright 1997, Okidata, Division of OKI America, Inc. All rights reserved. See the OKIDATA Business Partner Exchange (BPX) for any updates to this material. (<http://bpx.okidata.com>)

(5) Interface circuit

a) Receiving circuit

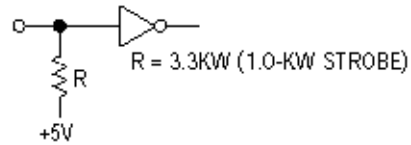

b) Sending circuit

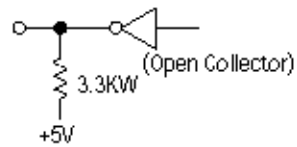



Service Guide OKIPAGE4w
Chapter B Parallel Interface

(6) Timing charts

a) Data receiving timing (compatible mode)

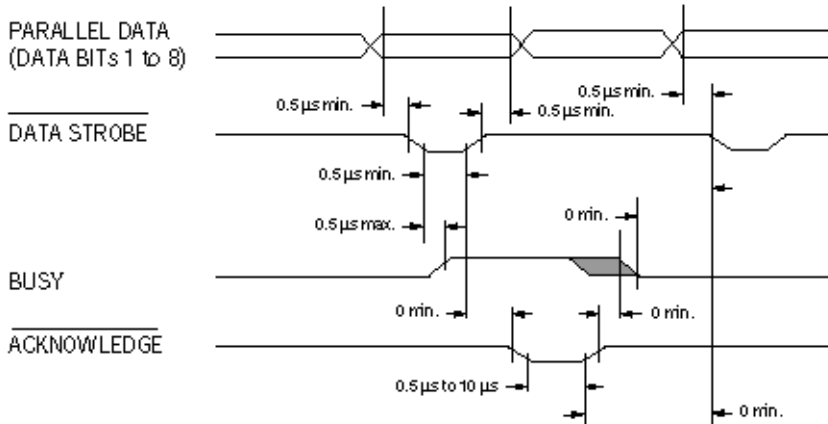

b) INPUT PRIME timing (when the INPUT PRIME signal is enabled)

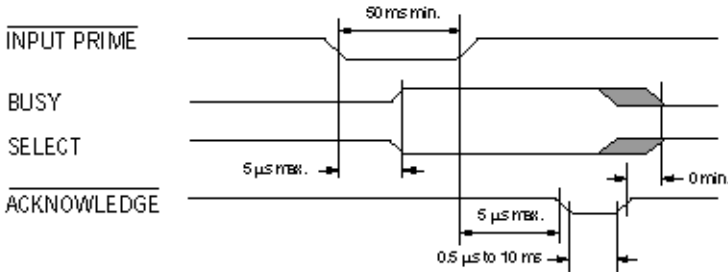

c) Data sending timing (nibble mode)

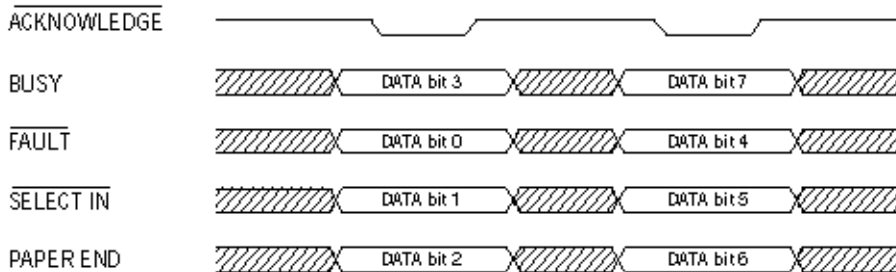

MAINTENANCE UTILITY**1. OUTLINE OF MAINTENANCE UTILITY**

The maintenance utility is an application program that operates on Microsoft Windows 3.1 or higher.

The maintenance utility has the following functions:

- Transmission of menu setting command to initialize and change setting values
 - Printer RAM check
 - Test printing
 - Printer information display
 - Printer EEPROM read/write
-

Copyright 1997, Okidata, Division of OKI America, Inc. All rights reserved. See the OKIDATA Business Partner Exchange (BPX) for any updates to this material. (<http://bpx.okidata.com>)



Service Guide OKIPAGE4w

Chapter C Maintenance Utility

2. ROLE OF MAINTENANCE UTILITY

The maintenance utility is a collection of command send/receive functions to perform printer maintenance functions.

For this reason, only service and maintenance personnel can use the maintenance utility. This utility cannot be made public for printer end users.

Copyright 1997, Okidata, Division of OKI America, Inc. All rights reserved. See the OKIDATA Business Partner Exchange (BPX) for any updates to this material. (<http://bpx.okidata.com>)

3. OUTLINE OF MAINTENANCE UTILITY FUNCTIONS

The maintenance utility is classified into the following functional units and displayed:

- Engine Menu Setting : Used to display and change engine menu settings.
- Engine Counter : Used to display and initialize the engine counter.
- Printer Status : Used to display the printer status.
- Test Print : Used to execute test printing.
- Option : Special function
- About : Used to display engine maintenance utility information and printer information.
- Reload : Used to reload menu setting values.

4. DETAIL OF EACH FUNCTION

4.1 Engine Menu Setting

Engine Menu Setting is used to set, display, and change the following menu items: (See Figure C-1.)

(1) Print Position

Used to adjust the print start position.

(2) LED Head Marking No.

Used to adjust the exposure time of the LED head.

(3) LED Head Width

Used to specify the LED head dot count.

(4) LED Head Wire

Used to specify whether the data wire of the LED head is one-wire (non-adjustment) type or two-wire (adjustment) type. (This printer, however, can use only one-wire type.)

(5) Setting or Humidity

Used to adjust transfer current.

(6) Entry

Used to reflect the engine menu setting values on the printer.

(7) Cancel

Used to clear unreflected items. (Items for which Entry is not specified.)

Engine Counter

Engine Counter is used to display and initialize the following count values: **(See Figure C-1.)** 

(1) Drum Count

Number of revolutions of mounted image drum

(2) Total Drum Count

Total number of revolutions of image drum after shipment

(3) Page Count

Total number of printed pages after shipment

Note: Clicking the "Reset" button clears each counter.

(4) Reset All

Used to clear all counters.



Service Guide OKIPAGE4w

Chapter C Maintenance Utility

4.8 Exit

Clicking the Exit button terminates the maintenance utility.

Engine Maintenance Driver GUI (Preliminary)

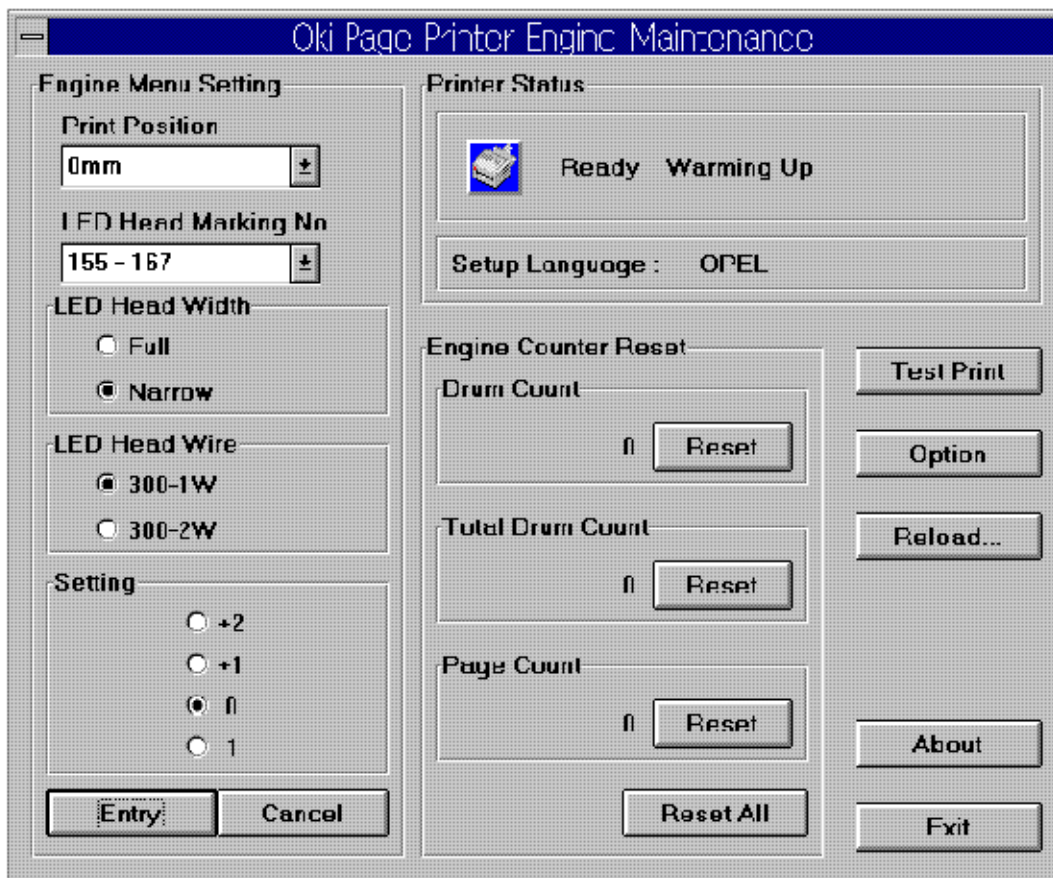

Figure C-1 Main Menu Dialog (Preliminary)

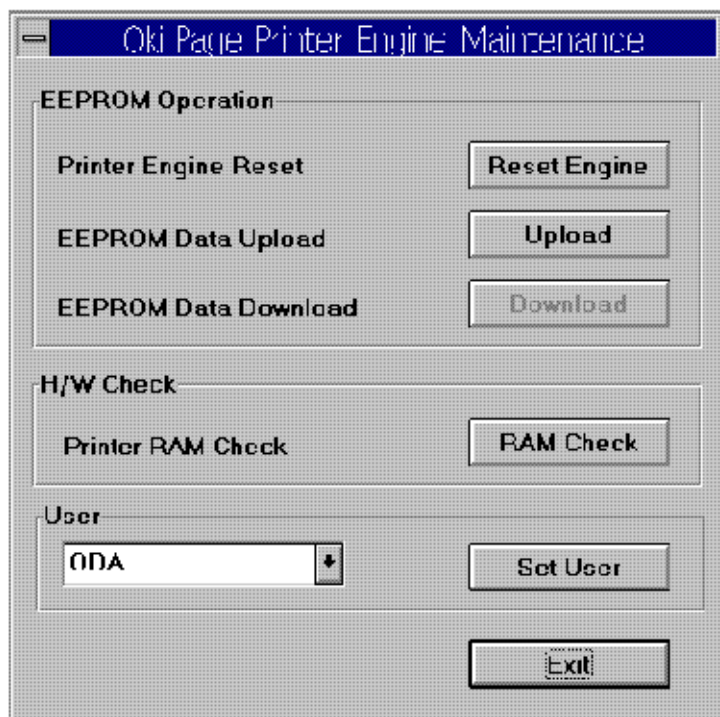

Figure C-2 Option Menu Dialog (Preliminary)

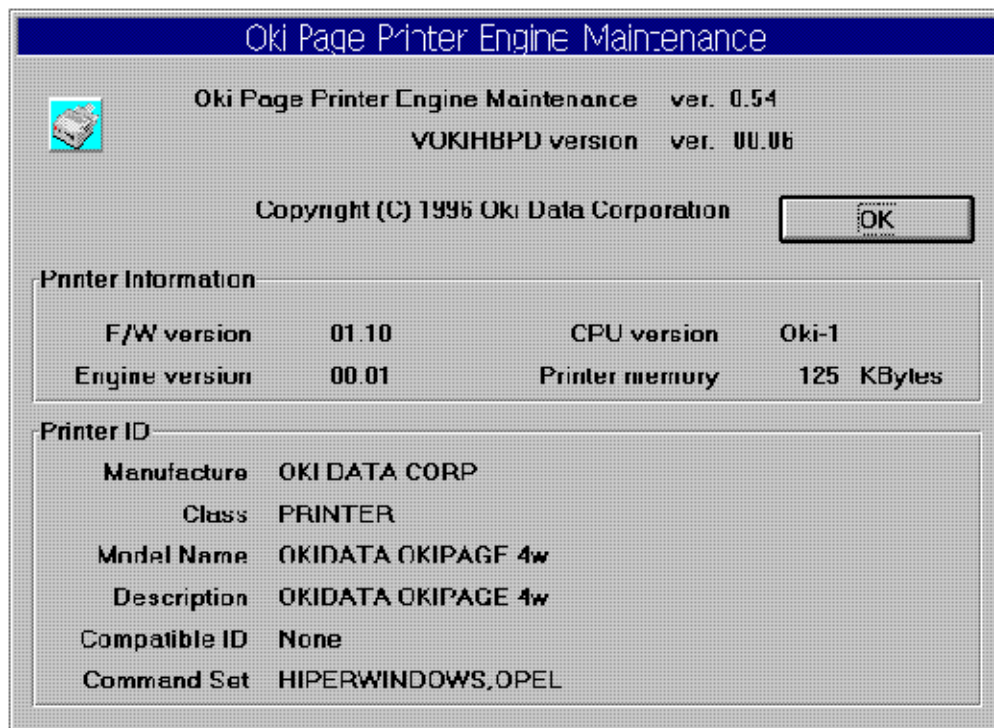



Figure C-3 About Dialog (Preliminary)



Service Guide OKIPAGE4w

Chapter C Maintenance Utility

4.3 Printer Status

Printer Status is used to display the printer status. **(See Figure C-1.)** 

Copyright 1997, Okidata, Division of OKI America, Inc. All rights reserved. See the OKIDATA Business Partner Exchange (BPX) for any updates to this material. (<http://bpx.okidata.com>)



4.4 Test Print

Test Print is used to check whether the printer can print data normally after the maintenance utility has terminated.

Copyright 1997, Okidata, Division of OKI America, Inc. All rights reserved. See the OKIDATA Business Partner Exchange (BPX) for any updates to this material. (<http://bpx.okidata.com>)



Service Guide OKIPAGE4w

Chapter C Maintenance Utility

4.5 Option

Option is used to execute the following functions:

(1) Printer Engine Reset

Initializes the engine menu and counter.

(2) EEPROM Upload

Uploads EEPROM contents to the file.

(3) EEPROM Download

Downloads data from the file to EEPROM.

(4) Printer RAM Check

Checks printer RAM.

(5) User

Sets a destination default (ODA, OEL, INTL, INTA). **See Figure C-2.** 



Service Guide OKIPAGE4w

Chapter C Maintenance Utility

4.6 About

About displays the following information:

Engine maintenance utility version information
Printer version information and memory size information
Printer device ID information

See figure C-3. 

Copyright 1997, Okidata, Division of OKI America, Inc. All rights reserved. See the OKIDATA Business Partner Exchange (BPX) for any updates to this material. (<http://bpx.okidata.com>)



4.7 Reload

Reload is used to reload menu setting values.

Copyright 1997, Okidata, Division of OKI America, Inc. All rights reserved. See the OKIDATA Business Partner Exchange (BPX) for any updates to this material. (<http://bpx.okidata.com>)